

# ZSH 系列二位二通电磁阀(常开型)



## ZSH

二位二通电磁阀 (常开型)



ZS-10H



ZS-15HS2

### 产品特性

- \* 两位两通电磁阀，常开。有铜阀体不锈钢304阀体可供选择
- \* 有多种密封件可供选择，以适合不同的介质
- \* 接管口径从3/8" 到2"，也可以配法兰
- \* 膜片先导式电磁阀，耐压偏低
- \* 节能型功耗降低80%

### 外形尺寸图

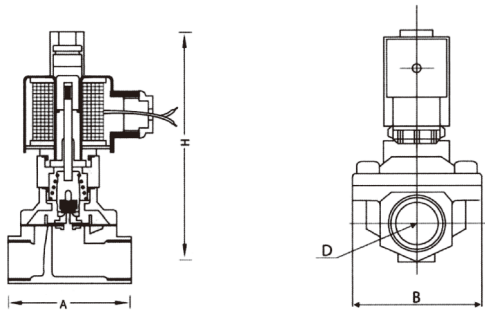

### 规格

接管口径	流量直径 (mm)	CV值	压力差 (Bar)								最大流体温度 (°C)	ZSH			ZSHN		订货型号 220VAC 50/60HZ		外形尺寸 长×宽×高 A×B×H(mm)
			最小压力		最大工作压力				VA AC220	W DC24V		W DC24V	黄铜	不锈钢304					
			空气、瓦斯	DC	水、热水、液体	DC	轻油 ≤20CST	AC							DC				
3/8"	4.0	0.6	0	5	3	5	3	3	3	80	33	20	4	ZS10H-040E2	ZS10H-040E2S2	52.5 × 32.5 × 115			
	4.0	0.6	0	5	3	5	3	-	-	120	33	20	4	ZS10H-040E2E	ZS10H-040E2S2E	52.5 × 32.5 × 115			
	4.0	0.6	0	5	3	5	3	3	3	120	33	20	4	ZS10H-040E2V	ZS10H-040E2S2V	52.5 × 32.5 × 115			
	16	4.8	0	5	3	3	5	3	3	80	33	20	4	ZS10H-160E2	ZS10H-160E2S2	69 × 57 × 135			
	16	4.8	0	5	3	3	5	-	-	120	33	20	4	ZS10H-160E2E	ZS10H-160E2S2E	69 × 57 × 135			
	16	4.8	0	5	3	3	5	3	3	120	33	20	4	ZS10H-160E2V	ZS10H-160E2S2V	69 × 57 × 135			
1/2"	16	4.8	0	5	3	5	3	3	3	80	33	20	4	ZS15H-160E2	ZS15H-160E2S2	69 × 57 × 135			
	16	4.8	0	5	3	5	3	-	-	120	33	20	4	ZS15H-160E2E	ZS15H-160E2S2E	69 × 57 × 135			
	16	4.8	0	5	3	5	3	3	3	120	33	20	4	ZS15H-160E2V	ZS15H-160E2S2V	69 × 57 × 135			
3/4"	20	7.6	0	5	3	5	3	3	3	80	33	20	4	ZS20HE2	ZS20HE2S2	73 × 57 × 142			
	20	7.6	0	5	3	5	3	-	-	120	33	20	4	ZS20HE2E	ZS20HE2S2E	73 × 57 × 142			
	20	7.6	0	5	3	5	3	3	3	120	33	20	4	ZS20HE2V	ZS20HE2S2V	73 × 57 × 142			
1"	25	12	0	5	3	5	3	3	3	80	33	20	4	ZS25HE2	ZS25HE2S2	99 × 77.5 × 150			
	25	12	0	5	3	5	3	-	-	120	33	20	4	ZS25HE2E	ZS25HE2S2E	99 × 77.5 × 150			
	25	12	0	5	3	5	3	3	3	120	33	20	4	ZS25HE2V	ZS25HE2S2V	99 × 77.5 × 150			
	32	24	0	5	3	5	3	3	3	80	70	55	-	ZS32HE2	ZS32HE2S2	112 × 86.5 × 180			
1-1/4"	32	24	0	5	3	5	3	-	-	120	70	55	-	ZS32HE2E	ZS32HE2S2E	112 × 86.5 × 180			
	32	24	0	5	3	5	3	3	3	120	70	55	-	ZS32HE2V	ZS32HE2S2V	112 × 86.5 × 180			
1-1/2"	40	29	0	5	3	5	3	3	3	80	70	55	-	ZS40HE2	ZS40HE2S2	123 × 94 × 190			
	40	29	0	5	3	5	3	-	-	120	70	55	-	ZS40HE2E	ZS40HE2S2E	123 × 94 × 190			
	40	29	0	5	3	5	3	3	3	120	70	55	-	ZS40HE2V	ZS40HE2S2V	123 × 94 × 190			
2"	50	48	0	5	3	5	3	3	3	80	70	55	-	ZS50HE2	ZS50HE2S2	168 × 123 × 216			
	50	48	0	5	3	5	3	-	-	120	70	55	-	ZS50HE2E	ZS50HE2S2E	168 × 123 × 216			
	50	48	0	5	3	5	3	3	3	120	70	55	-	ZS50HE2V	ZS50HE2S2V	168 × 123 × 216			
	50	48	0	5	3	5	3	3	3	80	57	32	6	-	ZSF25HE2S2	140 × 115 × 180			
法兰 4孔	25	12	0	5	3	5	3	-	-	120	57	32	6	-	ZSF25HE2S2E	140 × 115 × 180			
	25	12	0	5	3	5	3	3	3	120	57	32	6	-	ZSF25HE2S2V	140 × 115 × 180			
	32	24	0	5	3	5	3	3	3	80	70	55	-	-	ZSF32HE2S2	152 × 135 × 235			
	32	24	0	5	3	5	3	-	-	120	70	55	-	-	ZSF32HE2S2E	152 × 135 × 235			
	32	24	0	5	3	5	3	3	3	120	70	55	-	-	ZSF32HE2S2V	152 × 135 × 235			
	40	29	0	5	3	5	3	3	3	80	70	55	-	-	ZSF40HE2S2	152 × 145 × 240			
	40	29	0	5	3	5	3	-	-	120	70	55	-	-	ZSF40HE2S2E	152 × 145 × 240			
	40	29	0	5	3	5	3	3	3	120	70	55	-	-	ZSF40HE2S2V	152 × 145 × 240			
	50	48	0	5	3	5	3	3	3	80	70	55	-	-	ZSF50HE2S2	195 × 160 × 255			
	50	48	0	5	3	5	3	-	-	120	70	55	-	-	ZSF50HE2S2E	195 × 160 × 255			
	50	48	0	5	3	5	3	3	3	120	70	55	-	-	ZSF50HE2S2V	195 × 160 × 255			