

EBM

Vacuum Generator

Vacuum Flow: 30 NL/min – 215 NL/min



EBM-A



EBM-B



EBM-C

Application/Features

- Products using multistage vacuum tube, engraved widely used in many industries.
- Rich choice of vacuum degree, so it can cope with a variety of working conditions.
- Small size, light weight, but with large vacuum flow.

	A type baseboard	1、 Air supply port 2、 Vacuum port 3、 Vent	Apply05、 10
	B type baseboard		Apply05、 10、 20、 30
	C type baseboard		Apply05、 10、 20、 30

How to Order?

Series No.	Specification	Baseboard Type	Sealing Material
EBM:EBM Series (vacuum degree: -84) EBX: EBX Series (vacuum degree: -91)	05: 1 vacuum tubes 10: 2 vacuum tubes 20: 4 vacuum tubes 30: 6 vacuum tubes	A: ϕ 6 pipe with pagoda connector, built-in muffler B: G1/8 internal thread, built-in muffler C: internal thread, external muffler	N: Nitrile rubber (default) V: Fluororubber

Order Example: EBM series vacuum generator, 1 set of vacuum tube, ϕ 6 gas pipe pagoda tip built-in muffler, NBR, Order code is: EBM05-A-V

Performance Parameter

Specifications And Models	Supply Gas Pressure(MPa)	Maximum Vacuum Degree(-kPa)	Maximum Vacuum Flow (NL/min)	Gas Consumption(NL/min)	Recommended Diameter Of Air Supply Port (mm)	Recommended Pipe Diameter For Vacuum Port (mm)
EBM05	0.45	84	35	26	6	8
EBM10	0.45	84	70	52	6	10
EBM20	0.45	84	141	107	8	12
EBM30	0.6	84	215	155	8	12
EBX05	0.45	91	30	24	6	8
EBX10	0.45	91	52	49	6	10
EBX20	0.45	91	110	105	8	12
EBX30	0.6	91	180	154	8	12

EBM Series Vacuum Generator



☉ Vacuum Flow Rate Of Different Vacuum Degrees (-kpa) (NL/min)

Specifications And Models	Air Supply Pressure (Mpa)	Gas Consumption (NL/min)	0	10	20	30	40	50	60	70	80	90	Maximum Vacuum Degree -Kpa
EBM05	0.45	26	35	17.5	13	11	10	8	5	2.5	0.8	--	84
EBM10	0.45	52	70	42	27	23	20	16	11	5	1.3	--	84
EBM20	0.45	107	141	72	50	44	38	32	20	11	3	--	84
EBM30	0.6	155	215	147	92	73	60	47	32	16	4.1	--	84
EBX05	0.45	24	30	15.5	10	9	9	6.5	5.5	3	1.5	0.5	91
EBX10	0.45	49	52	31	20	18	17	13	11	7	2.5	1.5	91
EBX20	0.45	105	110	62	38	32	30	22	14	12	8	3	91
EBX30	0.6	154	180	108	52	47	41	33	26	18	7.2	2.7	91

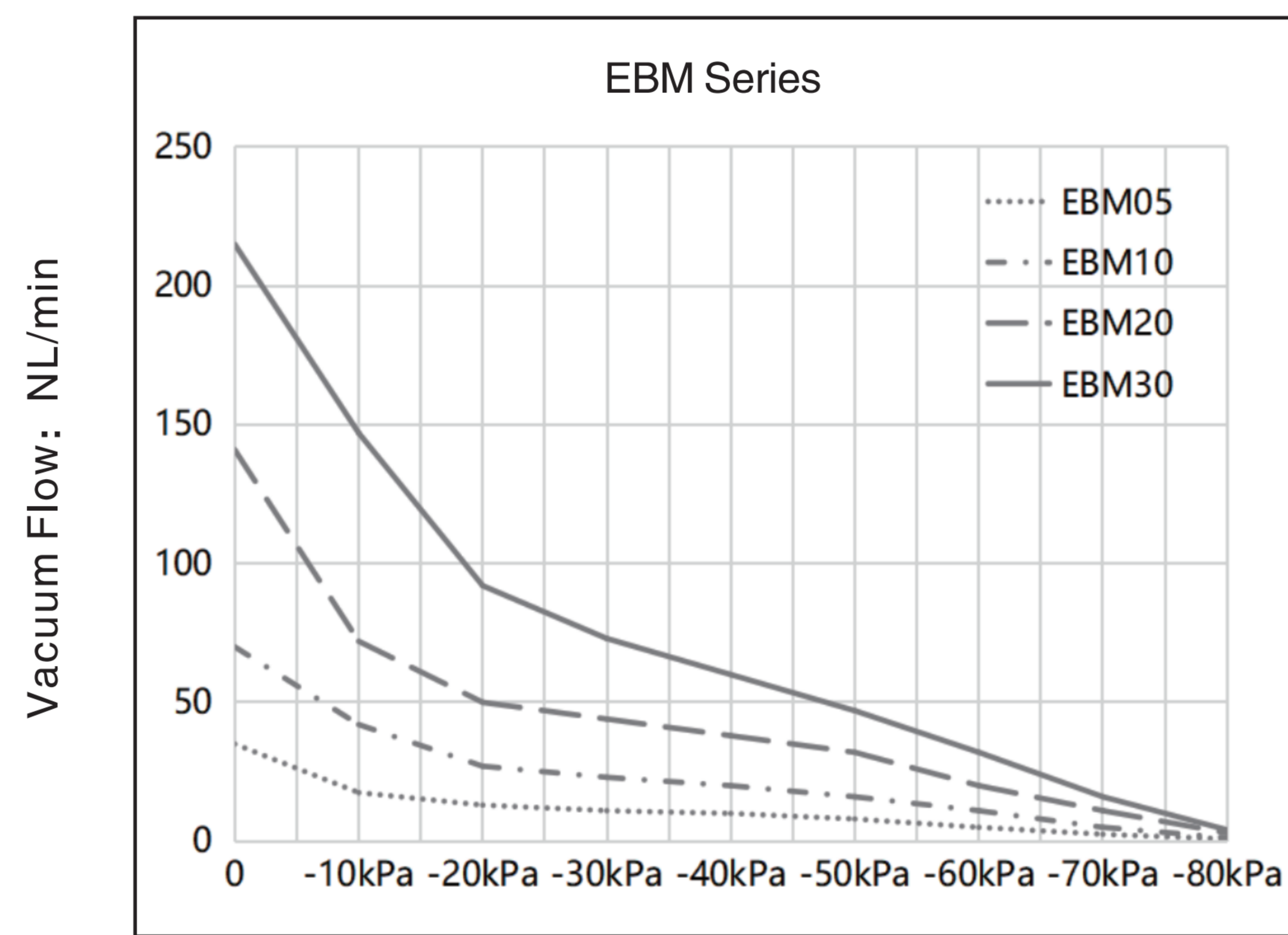

Vacuum Degree: -kPa

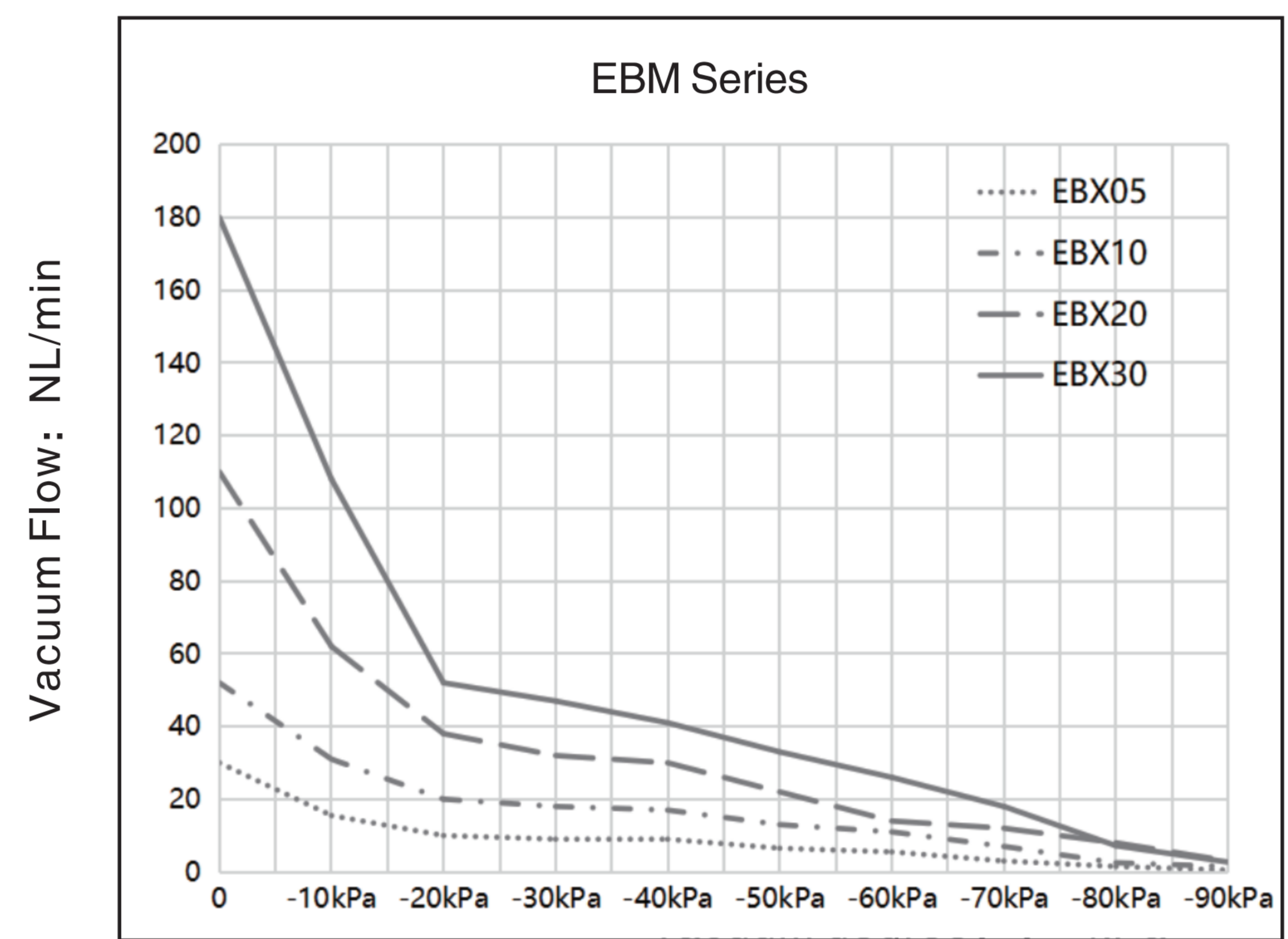

Vacuum Degree: -kPa

☉ Suction Time Of Different Vacuum Degrees (-kpa) (S/L)

Specifications And Models	Air Supply Pressure (Mpa)	Gas Consumption (NL/min)	0	10	20	30	40	50	60	70	80	90	Maximum Vacuum Degree -Kpa
EBM05	0.45	26	0	0.11	0.42	0.95	1.66	2.5	3.65	5.25	7.89	--	84
EBM10	0.45	52	0	0.08	0.2	0.44	0.8	1.24	1.8	2.55	3.8	--	84
EBM20	0.45	107	0	0.04	0.12	0.23	0.41	0.65	0.93	1.33	2.03	--	84
EBM30	0.6	155	0	0.040	0.010	0.186	0.310	0.490	0.650	0.900	1.900	--	84
EBX05	0.45	24	0	0.13	0.6	1.26	2.3	3.2	4.5	6.15	8.5	15.5	91
EBX10	0.45	49	0	0.11	0.3	0.65	1.1	1.55	2.15	2.85	4.7	10.2	91
EBX20	0.45	105	0	0.09	0.16	0.32	0.55	0.8	1.5	1.8	2.7	5.0	91
EBX30	0.6	154	0	0.05	0.15	0.28	0.44	0.67	0.92	1.3	1.9	3.6	91

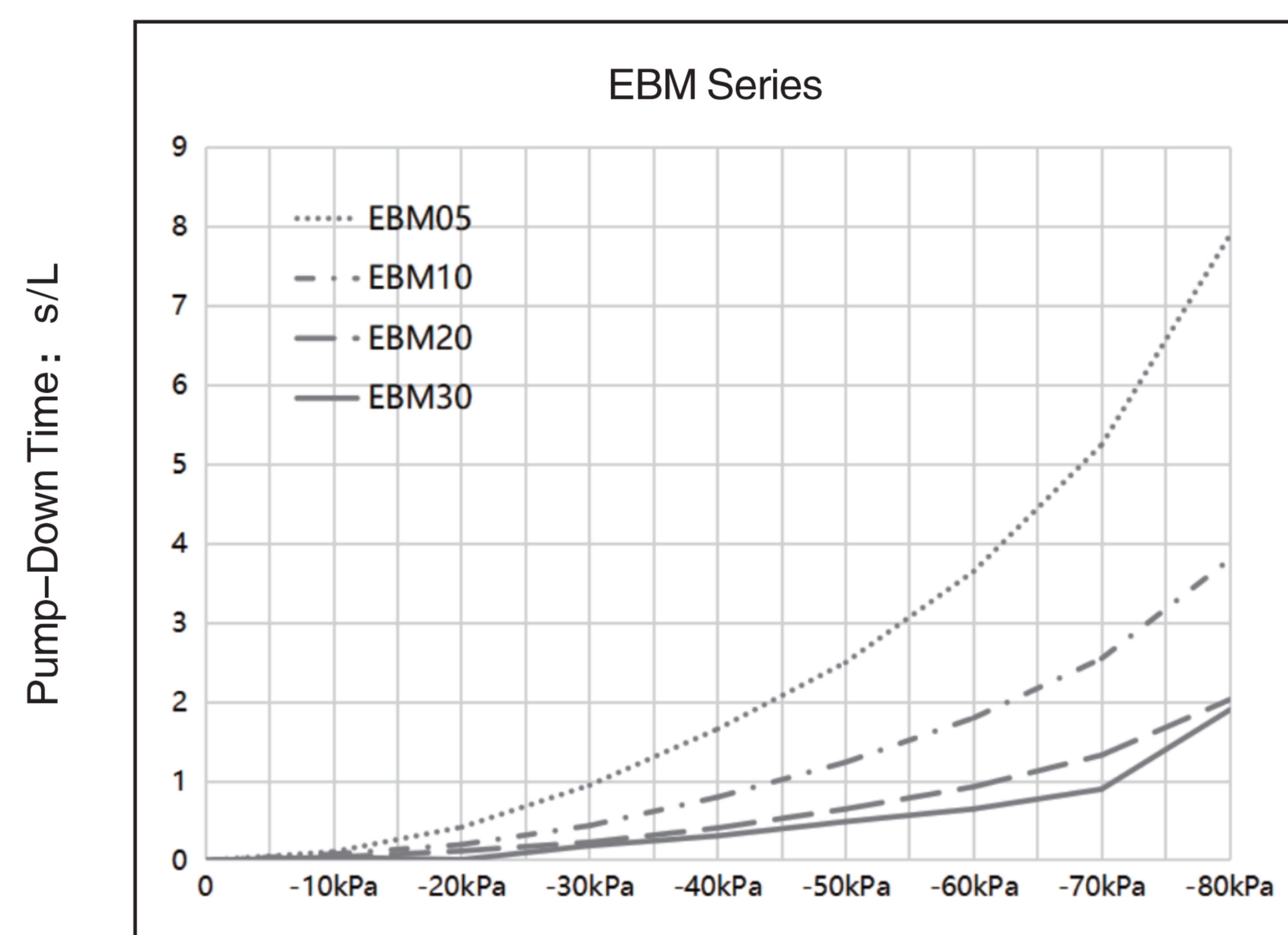

Vacuum : -kPa

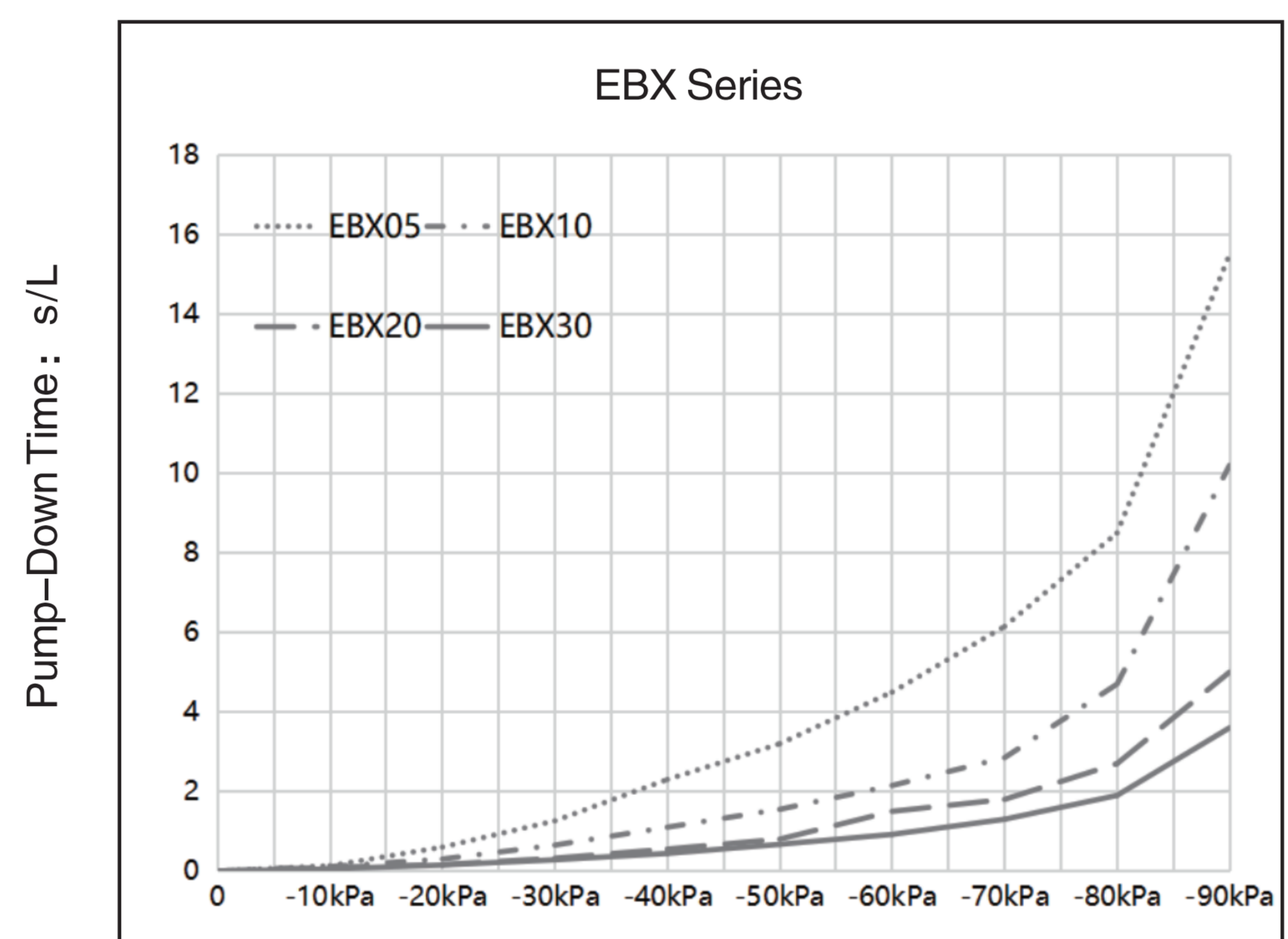

Vacuum : -kPa

Main Dimension

EBM/X (05、10) -A-

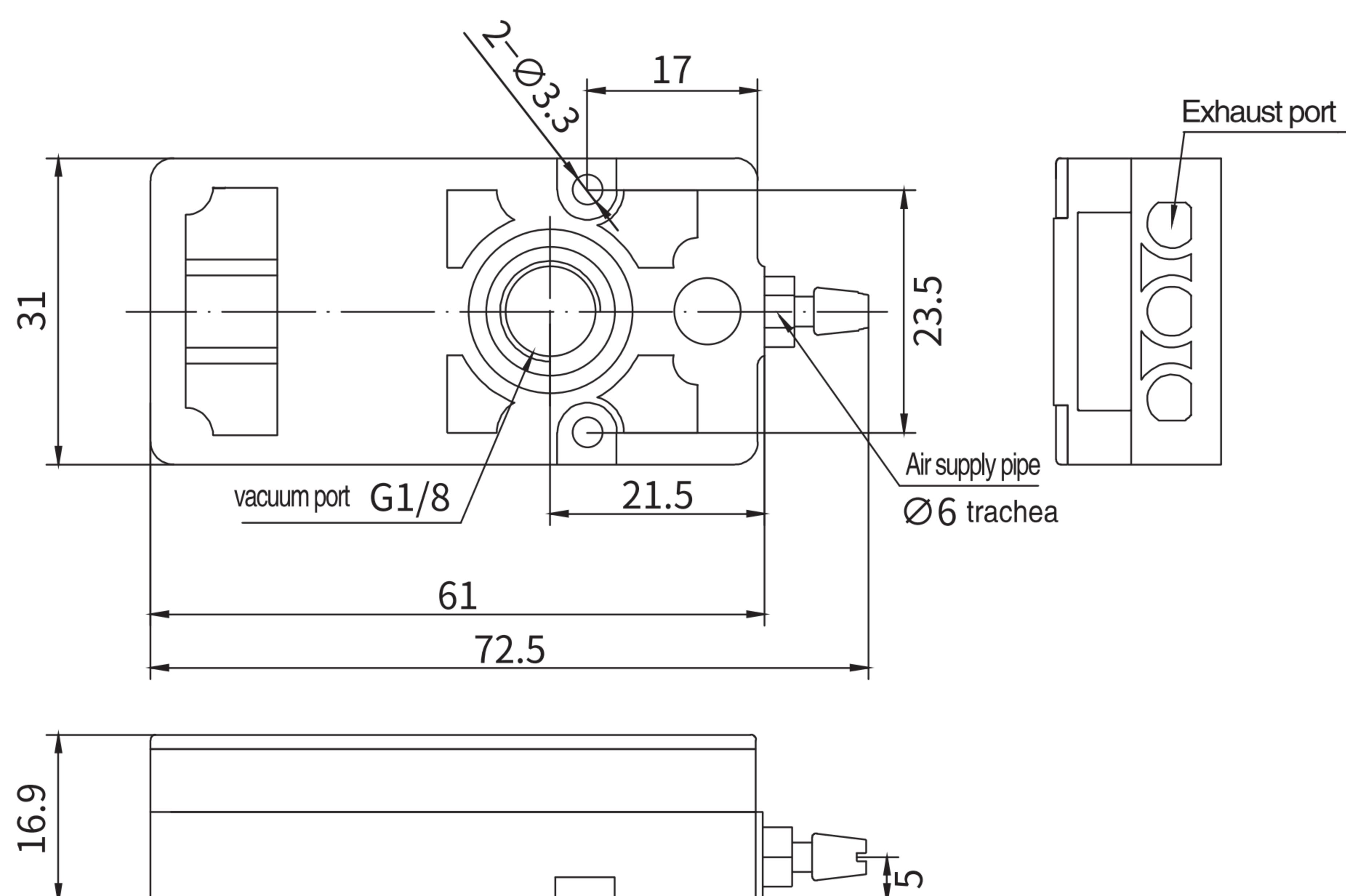

Specification	Jointed Sheet	Connecting Plate Specification	Air Supply Port Specifications	Vacuum Port Specification	Weight (g)
05	PA66	A	Ø6	G1/8	36
10	PA66		Ø6		35.5

EBM/X (05、10、20、30) -B-

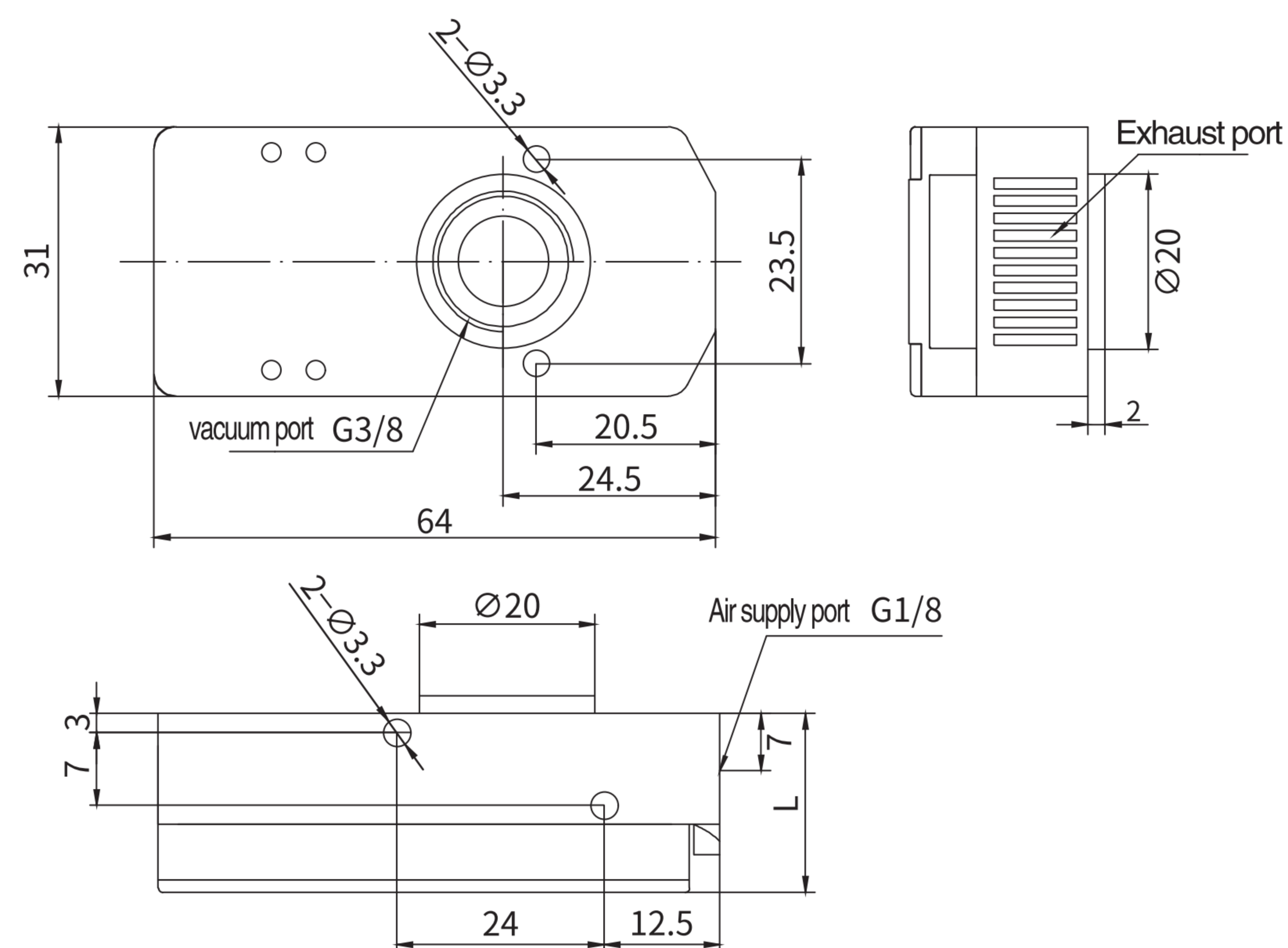

Specification	Jointed Sheet	Connecting Plate Specification	Air Supply Port Specifications	Vacuum Port Specification	L	Weight (g)
05	PA66	B	G1/8	G3/8	20.7	39.5
10	PA66				20.7	39
20	PA66				28	50
30	PA66				35	63

EBM/X (05、10、20、30) -C-

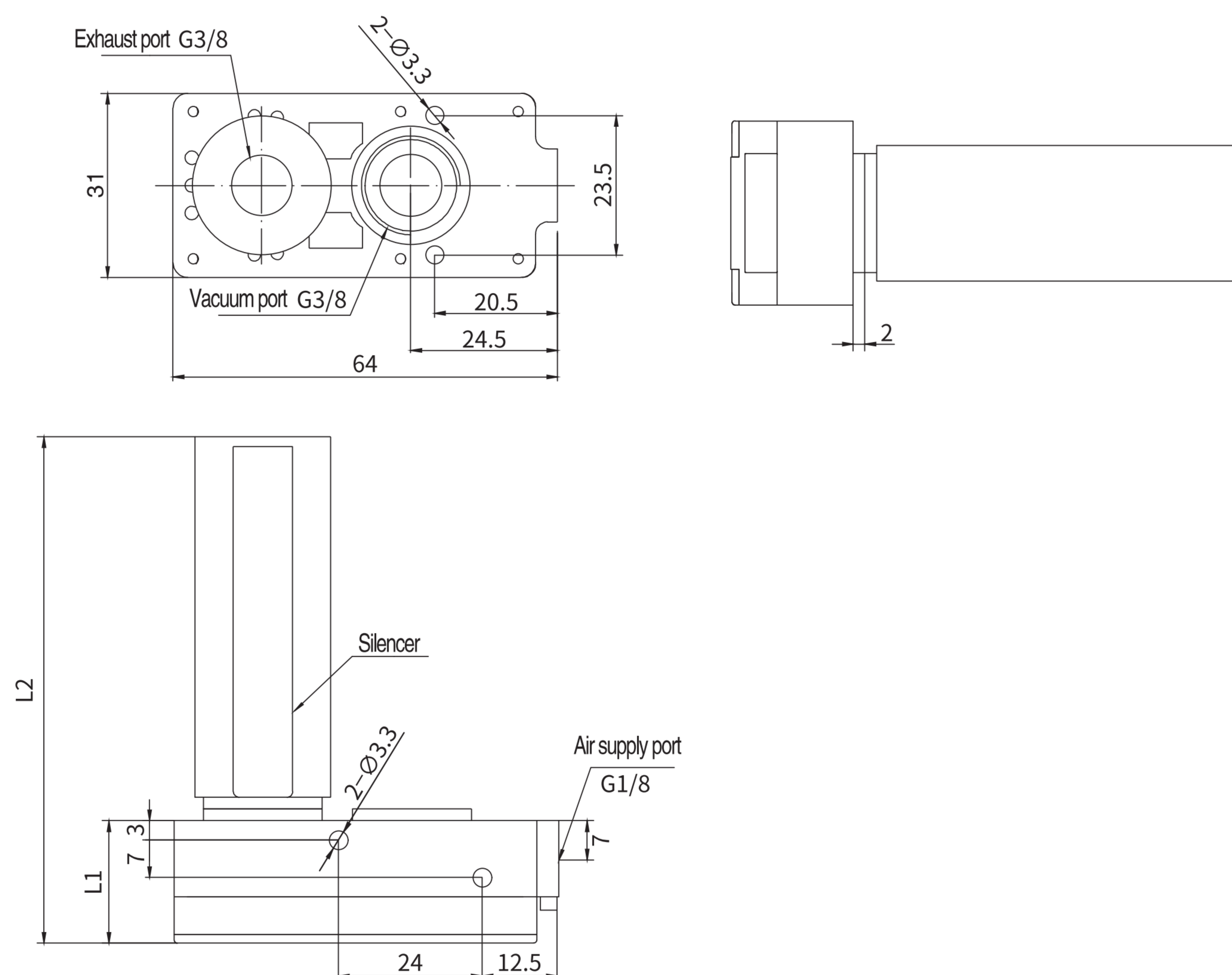

Specification	Jointed Sheet	Connecting Plate Specification	Air Supply Port Specifications	Vacuum Port Specification	L1	L2	Weight (g)
05	PA66	C	G1/8	G3/8	20.7	87	55
10	PA66				20.7	87	54.5
20	PA66				28	94.2	67
30	PA66				35	101.5	81