

## SQM

### Guide Rod Type Cylinder

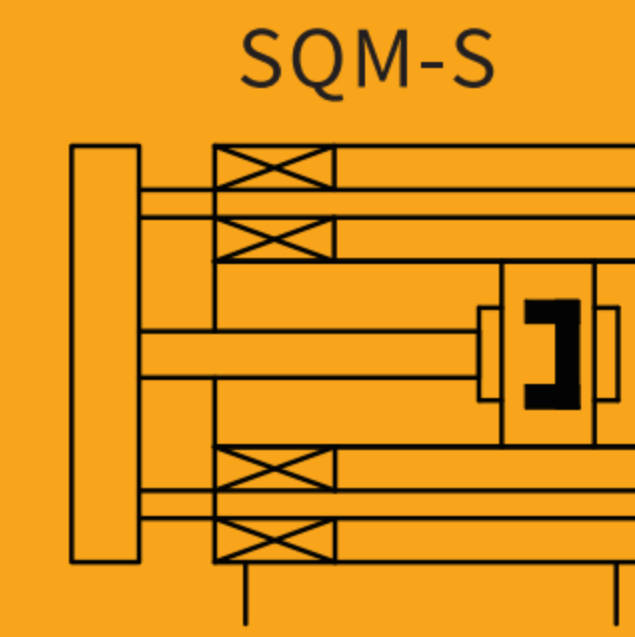
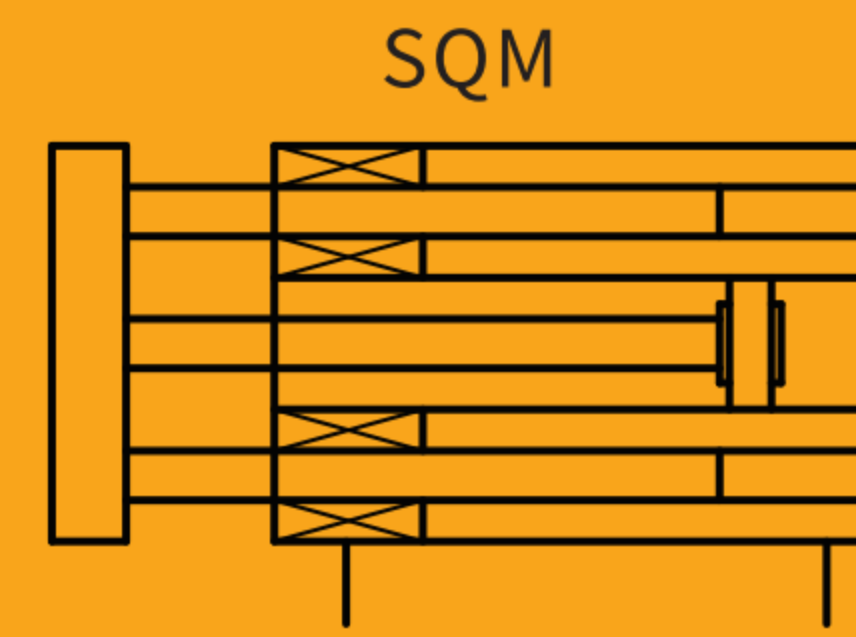

#### Specifications

Bore Size(mm)	12	16	20	25	32	40
Acting type	Double Acting					
Working medium	Clean Air (40 μ filtration)					
Working pressure (Mpa)	0.1~1.0					
Guaranteed pressure(Mpa)	1.5					
Working temperature	-20~70(No freezing)					
Speed range	30~500					
Stroke tolerance	+1.0 0					
Cushion type	Rubber cushion					
Port Size	M5X0.8				G1/8①	
Non-rotating tolerance	±0.2°			±0.1°		

① PT、NPT port size is optional.

#### How to Order?

Series No	Bore X Stroke	Magnet No	Thread Type
SQM	12 5 16 10 20 15 25 ... 32 40	Blank: No magnet S: With magnet	Blank: G P: PT T: NPT

#### Order Example:

SQM series basic type cylinder, 25mm bore, 20mm stroke, with magnet, G thread, no mounting, ERP code is: SQM 25X20-S

#### Optional Accessories

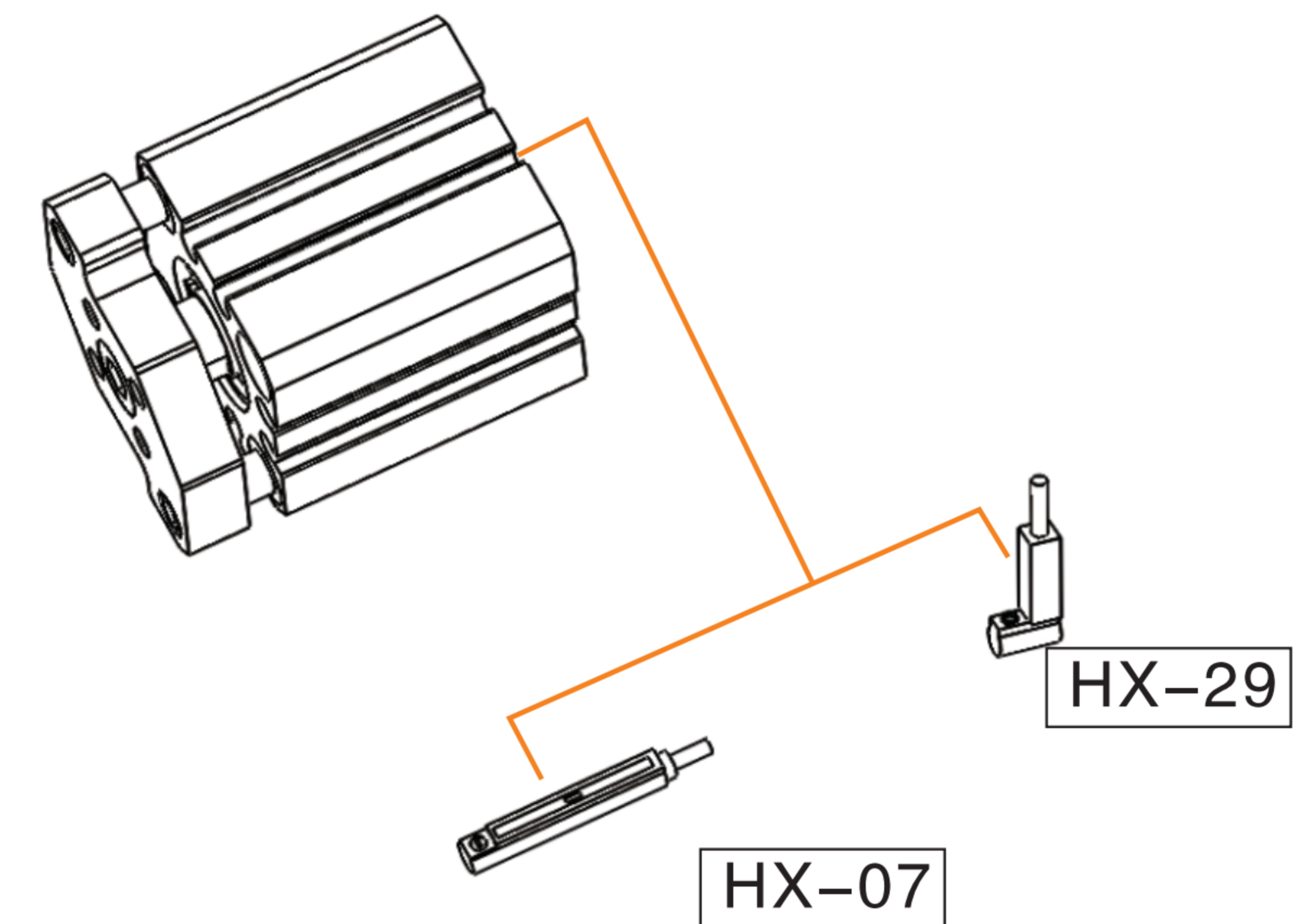

Note: Short stroke please use HX-29 series due to limited space.

#### Stroke

Bore (mm)	Standard Stroke (mm)	Max. Stroke (mm)
12、16	5 10 15 20 25 30	30
20、25	5 10 15 20 25 30 35 40 45 50	50
32、40	5 10 15 20 25 30 35 40 45 50 75 100	100

Note: The dimensions of non-std stroke cylinder has the same dimensions as the next longer stroke std. stroke cylinder.  
e.g. 27mm stroke cylinder has the same dimensions of 30 std. stroke cylinder.  
When ordering stroke is larger than the maximum stroke, please contact us.

#### Internal Structure

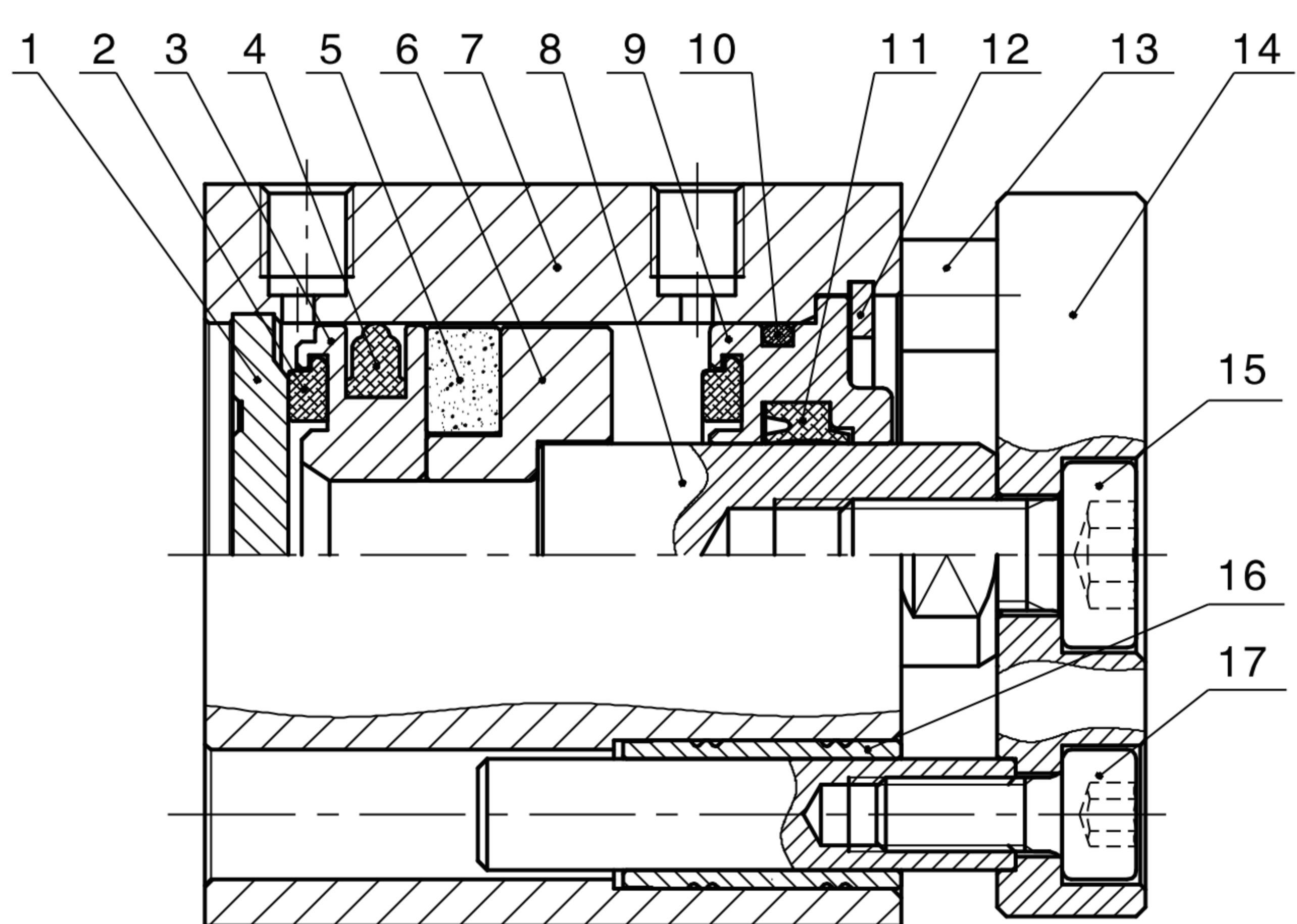

NO.	Part Name	Material
1	Rear cover	Aluminum alloy
2	Anti-bump cushion	TPU
3	Piston	Aluminum alloy
4	Piston seal	NBR
5	Integral magnet	RbFeB
6	Magnet base	Aluminum alloy
7	Barrel	Aluminum alloy
8	Piston rod	Carbon steel
9	head cover	Aluminum alloy
10	O-ring	NBR
11	Piston rod seal	TPU
12	C type retainer ring	Spring steel
13	Rod	Stainless steel
14	Fixed plate	Aluminum alloy
15	Hex socket cap screw	Carbon steel
16	Sliding bearing	Brass
17	Hex socket cap screw	Carbon steel

# SQM Series Compact Cylinder/Guide Rod Type



## ◎ Main Dimension

### SQMΦ12~25

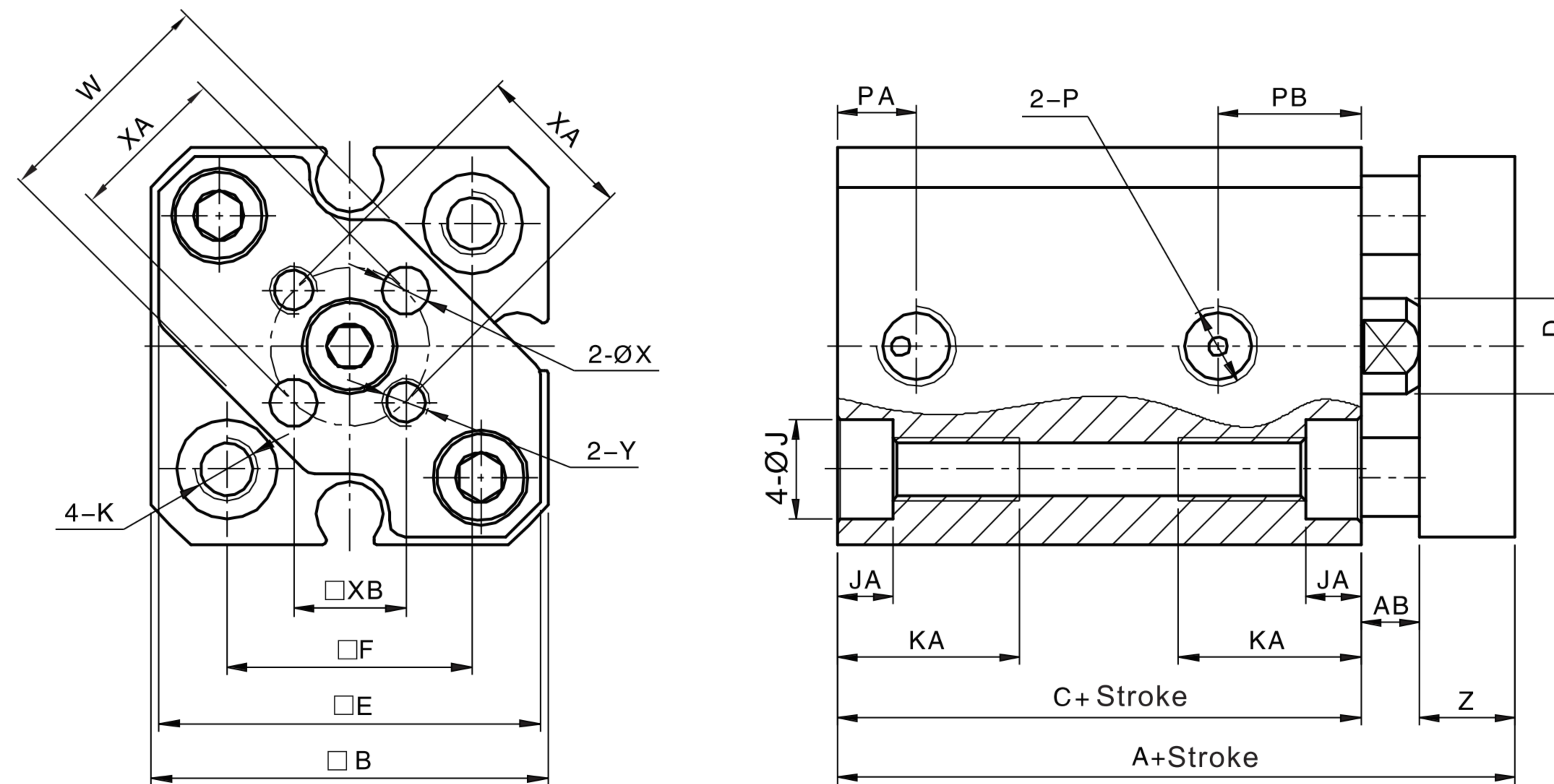

Bore/Sign	A		C		AB	B	D	E	F	J	JA	K
	Standard	With magnet	Standard	With magnet								
12	26.5	37.5	17	28	3.5	25	6	24	15.5	6.3	3.5	M4X0.7 Throgh hole: $\Phi$ 3.4
16	28	40	18.5	30.5	3.5	29	8	28	20	6.5	3.5	M4X0.7 Throgh hole: $\Phi$ 3.4
20	32	44	19.5	31.5	4.5	36	10	35	25.5	9	7	M6X1.0 Throgh hole: $\Phi$ 5.2
25	35.5	45.5	22.5	32.5	5	40	12	39	28	9	7	M6X1.0 Throgh hole: $\Phi$ 5.2

Bore/Sign	KA	P	PA	PB		W	X	XA	XB	Y	Z
12	11.5	M5X0.8	5	7.5	9	15	3	10	7.1	M3X0.5	6
16	11.5	M5X0.8	5.5	8	9.5	21	3	14	9.9	M3X0.5	6
20	18	M5X0.8	5.5	9	9	26	4	17	12	M4X0.7	8
25	17.5	M5X0.8	5.5	11	11	29	5	22	15.6	M5X0.8	8

### SQMΦ32、Φ40

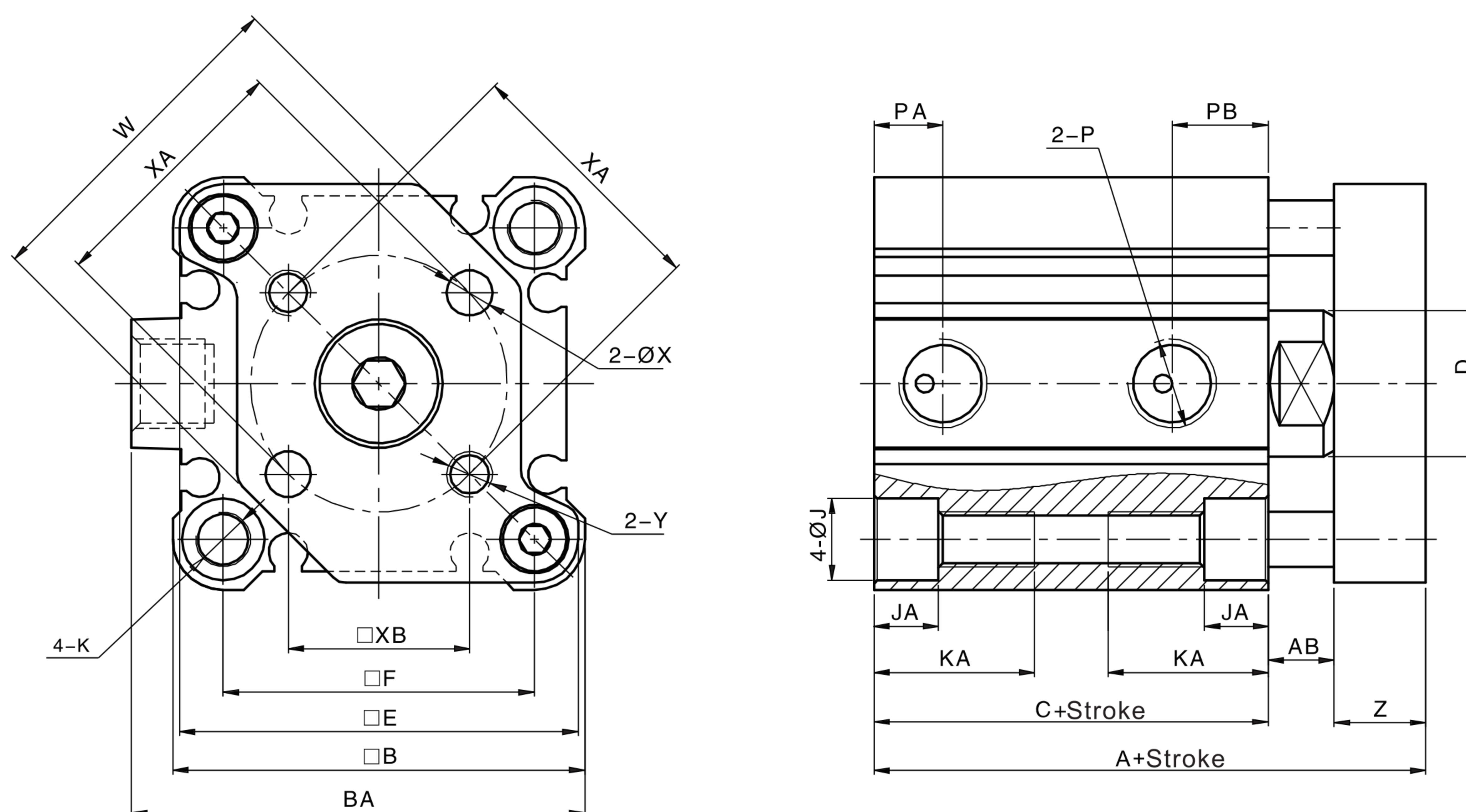

Bore/Sign	A		C		AB	B	BA	D	E	F	J	JA
	Standard	With magnet	Standard	With magnet								
32	40	50	23	33	7	45	49.5	16	43.5	34	9	3
40	46.5	56.5	29.5	39.5	7	52	57	16	50.5	40	9	3

Bore/Sign	K	KA	P	PA	PB	W	X	XA	XB	Y	Z
40	M6X1.0 Throgh hole: $\Phi$ 5.2	17.5	1/8"	8	11	46	5	33	23.3	M5X0.8	10