

EUP

Panel Cylinder

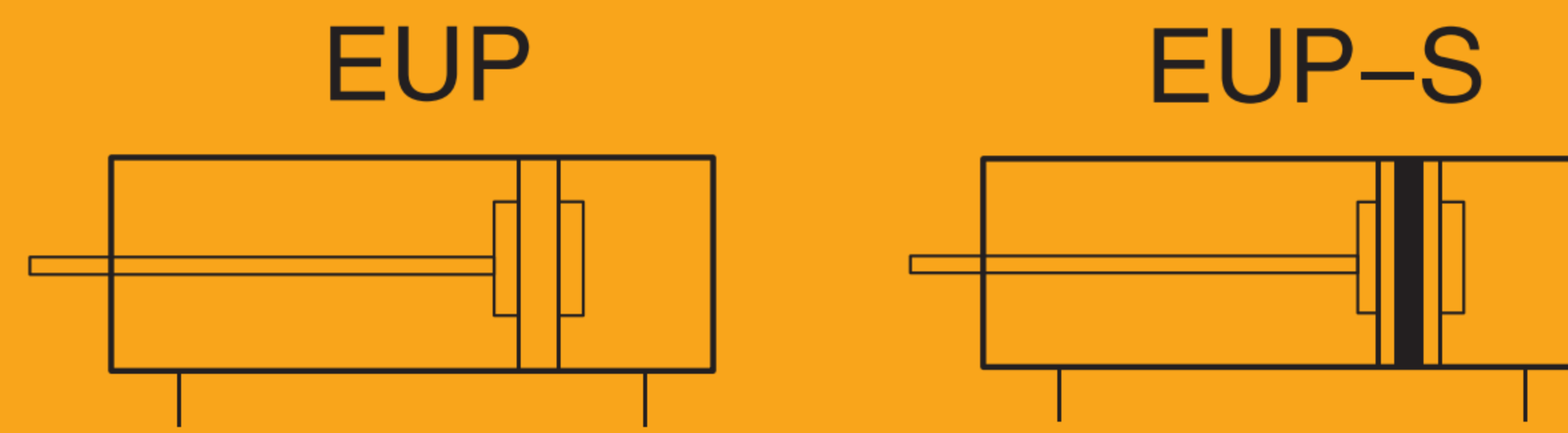

Specifications



Bore(mm)	6	10	16
Acting Type	Double Acting		
Working Medium	Clean Air(after 40 μ m filtration)		
Working Pressure(MPa)	0.1~0.7		
Guaranteed Pressure(MPa)	1.05		
Working Temperature(°C)	-20~70(No freezing)		
Piston Speed(mm/s)	30~500		
Stroke tolerance	+1.0 0		
Cushion	Rubber cushion		
Port Size	M3 × 0.5		M5 × 0.8

How to order?

Series No.	Type No.	Bore × Stroke	Magnet No.	Piston Rod Thread Type	Mounting Type
EUP	Blank: Basic type H: Rear hinge seat type	6 5 10 10 16 15 ...	Blank: No magnet S: With magnet	Blank: Male thread N: No thread	Blank: No CF CR

Order Example:

EUP series basic type cylinder, bore 10, stroke 50, with magnet, no mounting type.
The ERP code is: EUP10X50-S

Optional Accessories

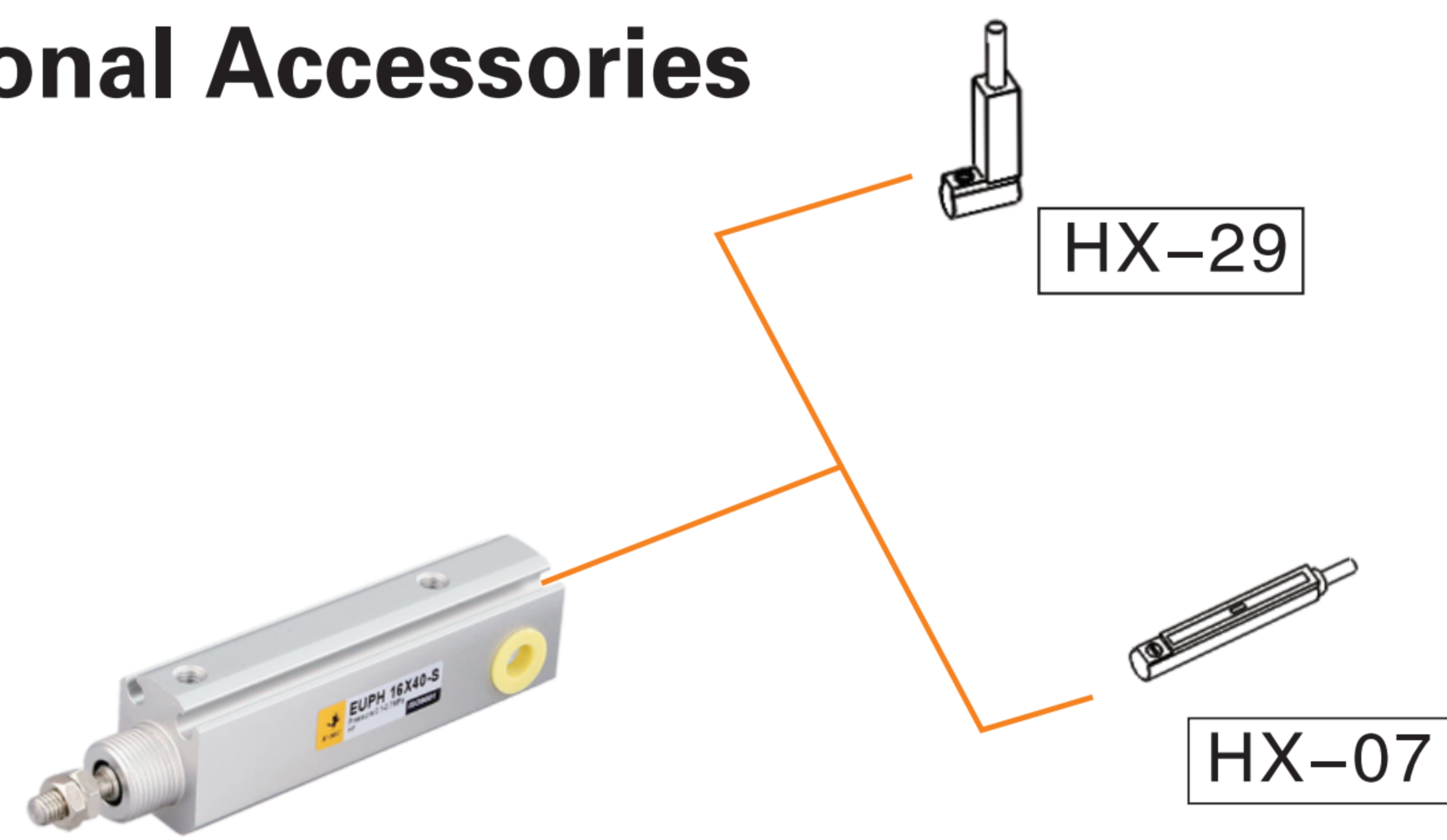

Note: Short stroke please use HX-29 series due to limited space.

Stroke

	Bore(mm)	Standard Stroke(mm)	Max. Stroke(mm)
Double Acting	6	5 10 15 20 25	25
	10	5 10 15 20 25 30 35 40	40
	16	5 10 15 20 25 30 35 40	40

Note: The dimensions of non-std stroke cylinder has the same dimensions as the next longer stroke std. stroke cylinder.
e.g. 27mm stroke cylinder has the same dimensions of 30 std. stroke cylinder.
When ordering stroke is larger than the maximum stroke, please contact us.

Internal Structure

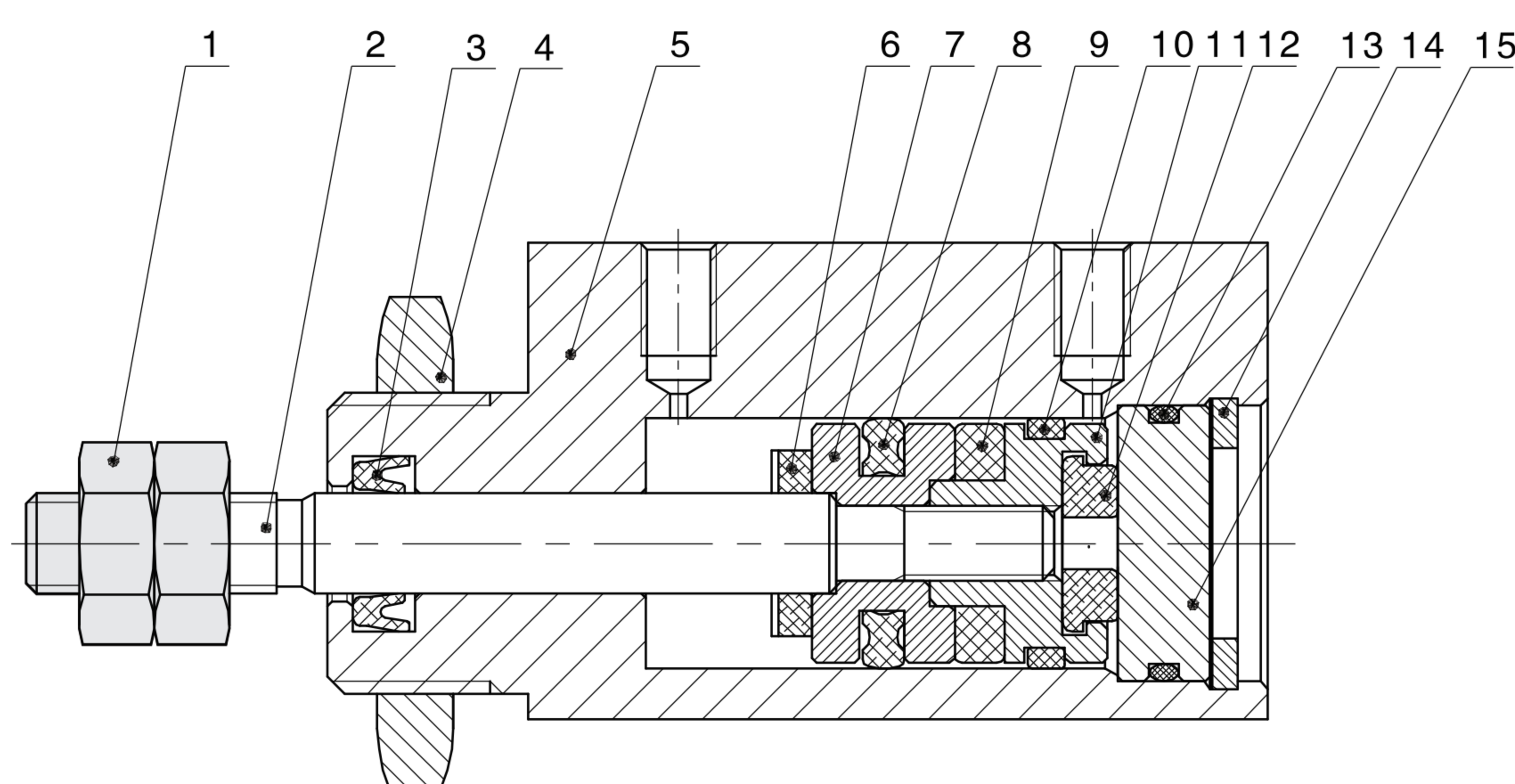

No.	Part Name	Material
1	Nut	Carbon steel
2	Piston Rod	SUS 304 hard chrome carbon steel
3	Front Cover o-ring	NBR
4	Nut	Carbon steel
5	Barrel	Aluminum Alloy
6	Anti-bump cushion	TPU
7	Piston	6: SUS304 10: Cu 16: Aluminum Alloy
8	Piston seal	NBR
9	Magnet	NdFeB
10	Wearing ring	PTFE
11	Magnet Seat	SUS304 16: Aluminum Alloy
12	Anti-bump cushion	TPU
13	O-ring	NBR
14	Snap ring	Spring steels
15	Rear Cover	Aluminum Alloy

EUP Series Panel Cylinder



◎ Main Dimensions

EUP

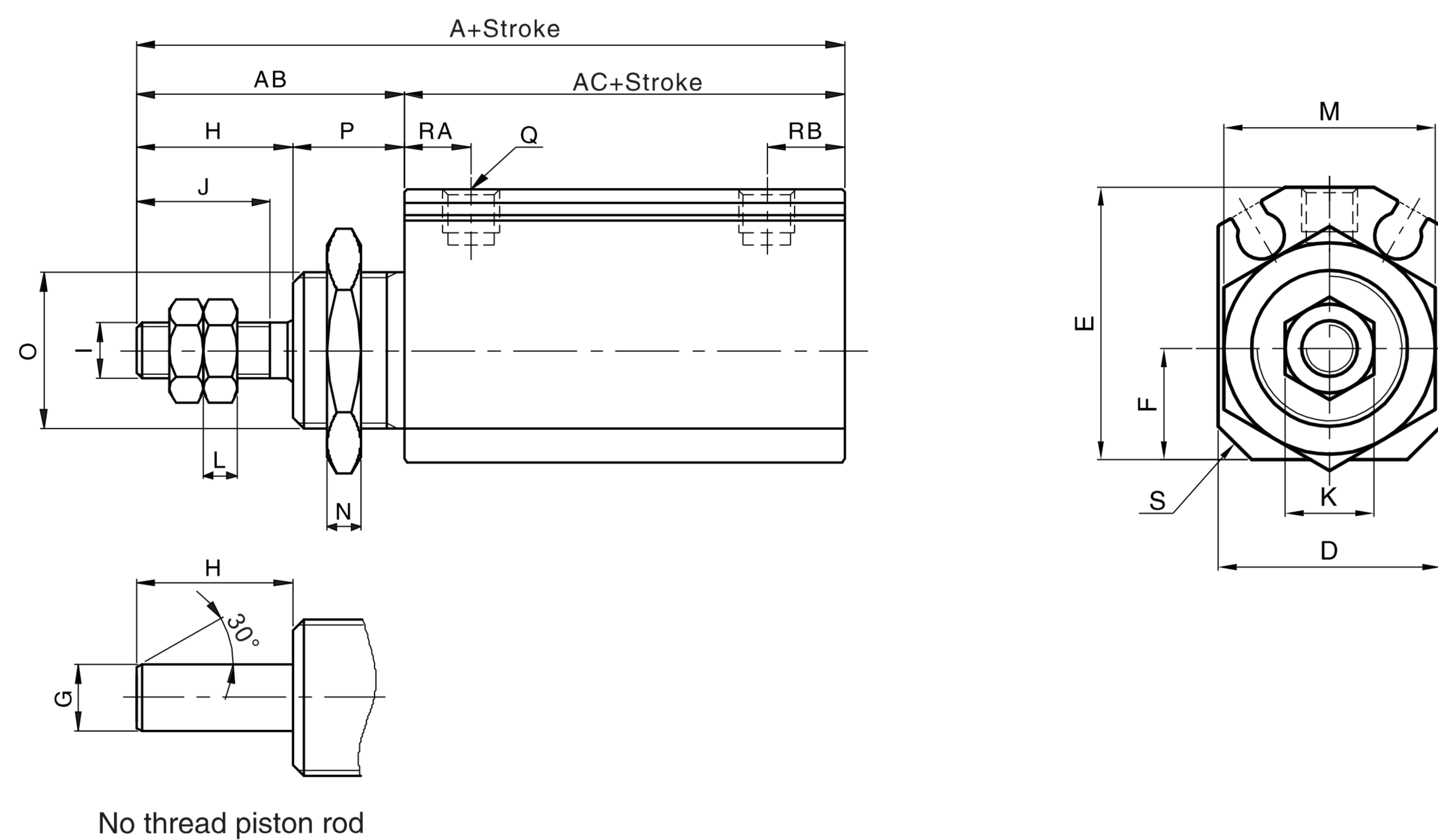

Bore/Sign	A		AB	AC		D	E	F	G	H	I	J	K	L	M	N	O	P	Q	RA	RB	S
	No magnet	With magnet		No magnet	With magnet																	
6	33	38	17	16	21	14	16.5	6	3	9	M3X0.5	7	5.5	2.5	12.7	3	M10X1.0	8	M3X0.5	4.6	6.5	2
10	39.5	44.5	20	19.5	24.5	15	19	7	4	12	M4X0.7	10	7	3	17	3	M12X1.0	8	M3X0.5	6	7	2.5
16	43.5	48.5	24	19.5	24.5	20	24.5	10	6	14	M5X0.8	12	8	3	19	3	M14X1.0	10	M5X0.8	6	7	3

EUPH

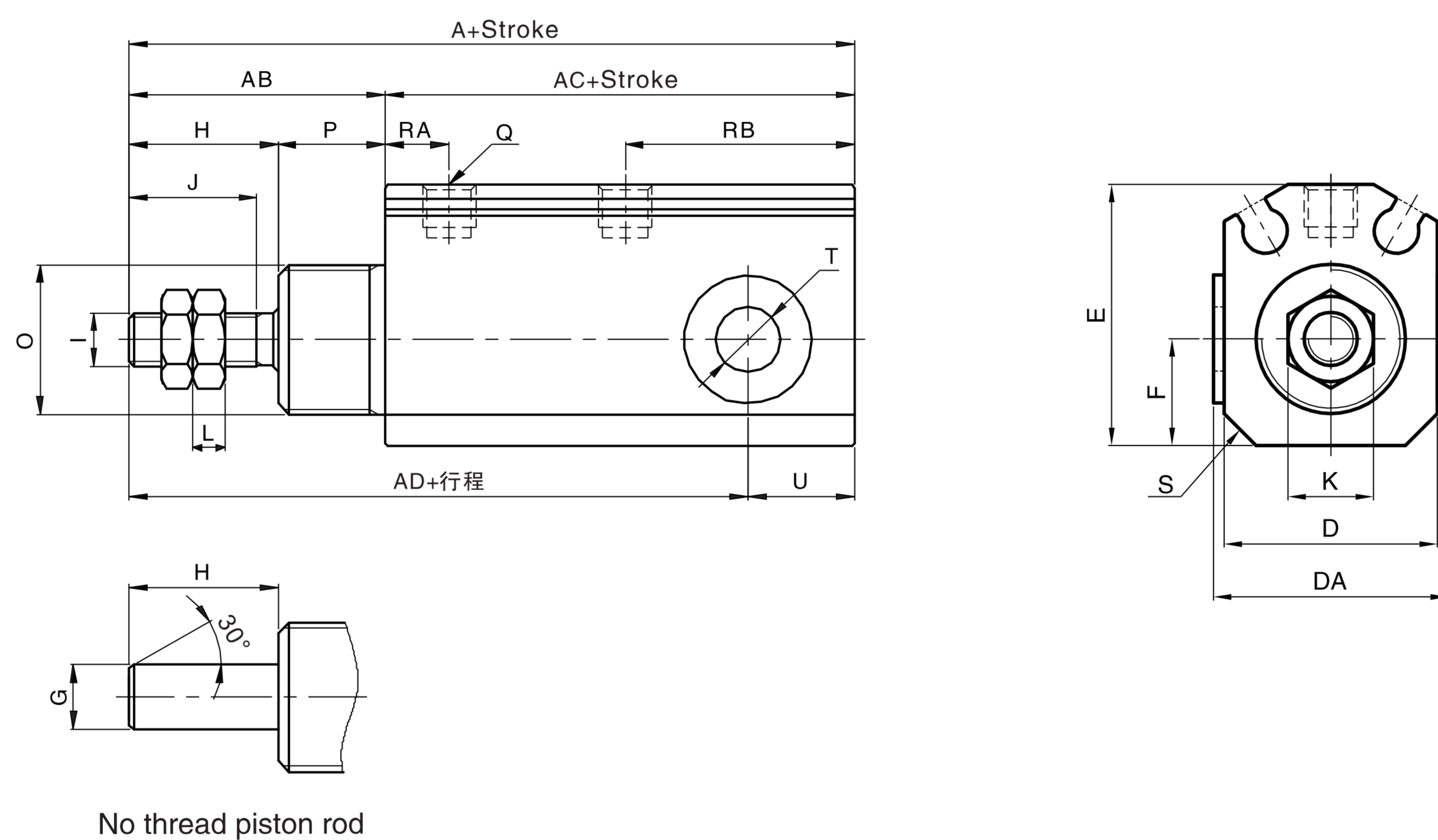

Bore/Sign	A		AB	AC		AD		D	DA	E	F	G	H	I	J	K	L
	No magnet	With magnet		No magnet	With magnet	No magnet	With magnet										
6	38	43	17	21	26	34	39	14	-	16.5	6	3	9	M3X0.5	7	5.5	2.5
10	50.5	55.5	20	30.5	35.5	44	49	15	17	19	7	4	12	M4X0.7	10	7	3
16	58	63	24	34	39	48	53	20	22	24.5	10	6	14	M5X0.8	12	8	3

Bore/Sign	O	P	Q	RA	RB	S	T	U
6	M10X1.0	8	M3X0.5	4.6	11.5	2	$\varnothing 3_{0}^{+0.05}$	4
10	M12X1.0	8	M3X0.5	6	18	2.5	$\varnothing 5_{0}^{+0.065}$	6.5
16	M14X1.0	10	M5X0.8	6	21.5	3	$\varnothing 6_{0}^{+0.065}$	10

Mounting Type

CR(Round head)

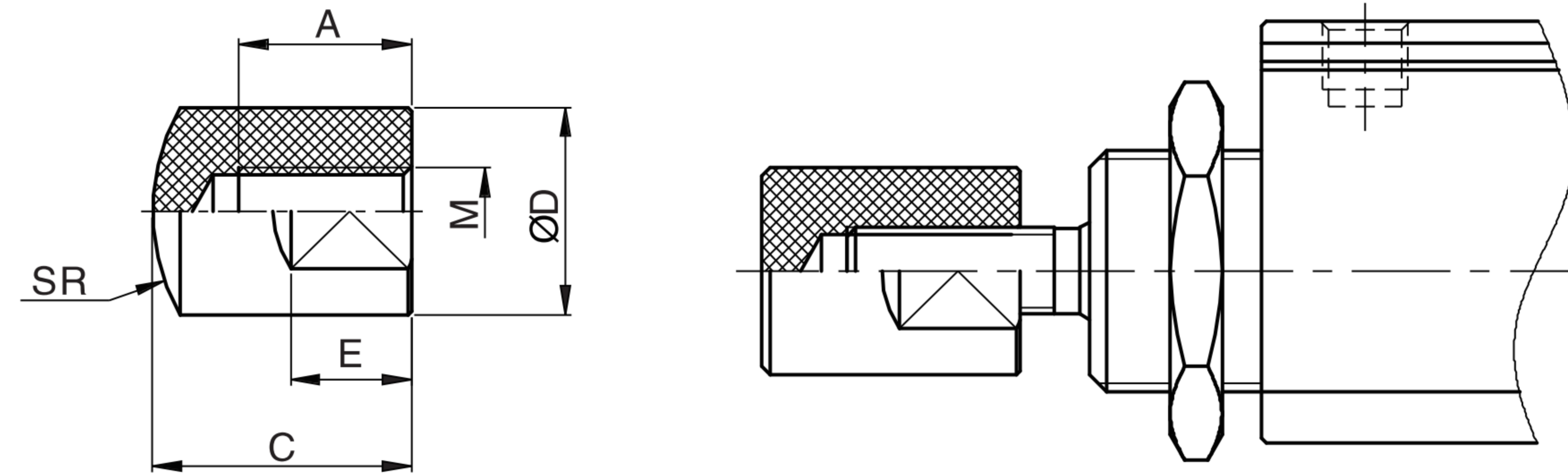

CF(Flat head)

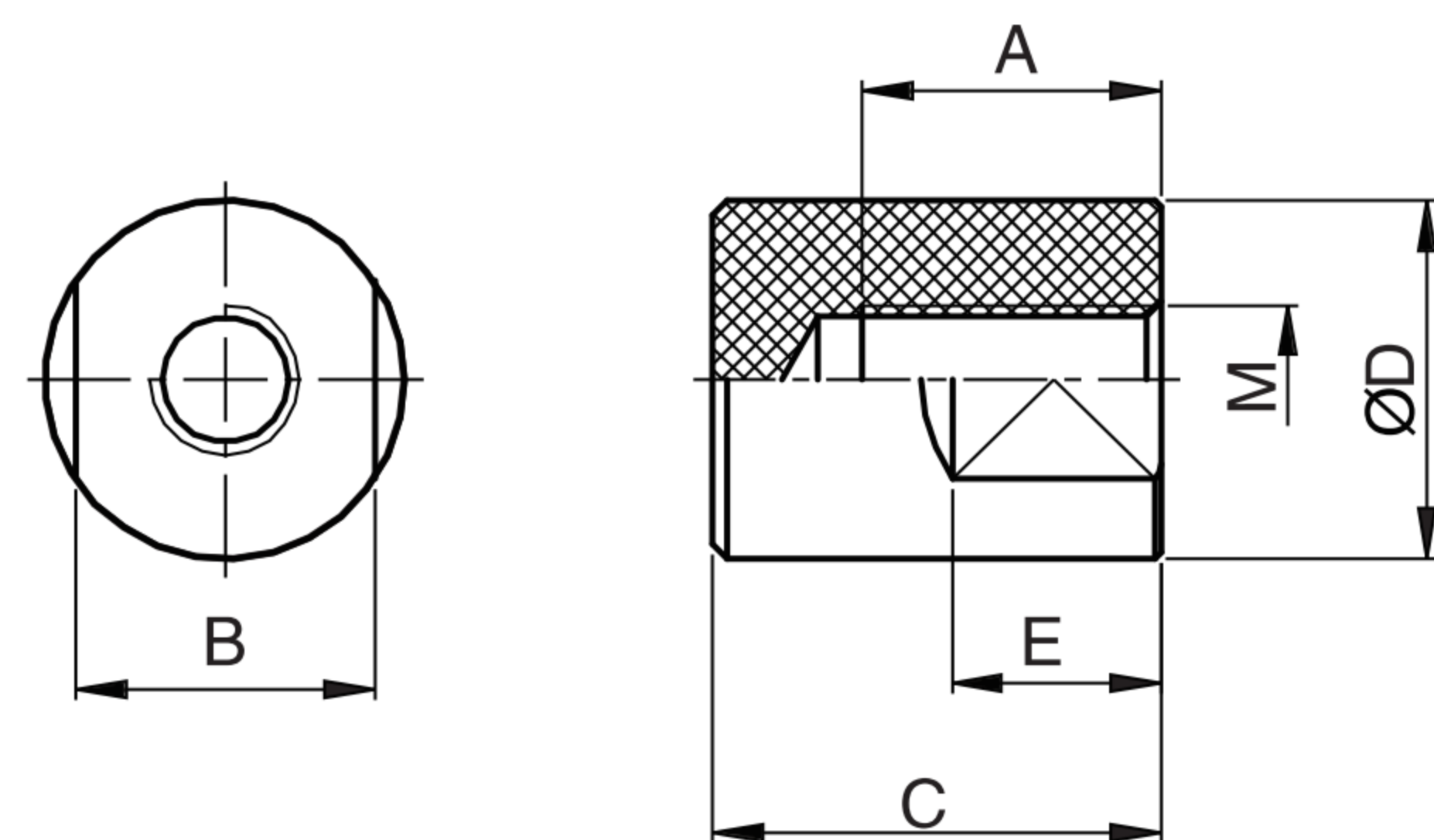

Bore/Sign	A	B	C	D	E	M	SR
FJ-EUP6CF/CR	6	6	11	8	5	M3X0.5	8
FJ-EUP10CF/CR	8	8	13	10	6	M4X0.7	10
FJ-EUP16CF/CR	10	10	15	12	7	M5X0.8	12

Installation and Use

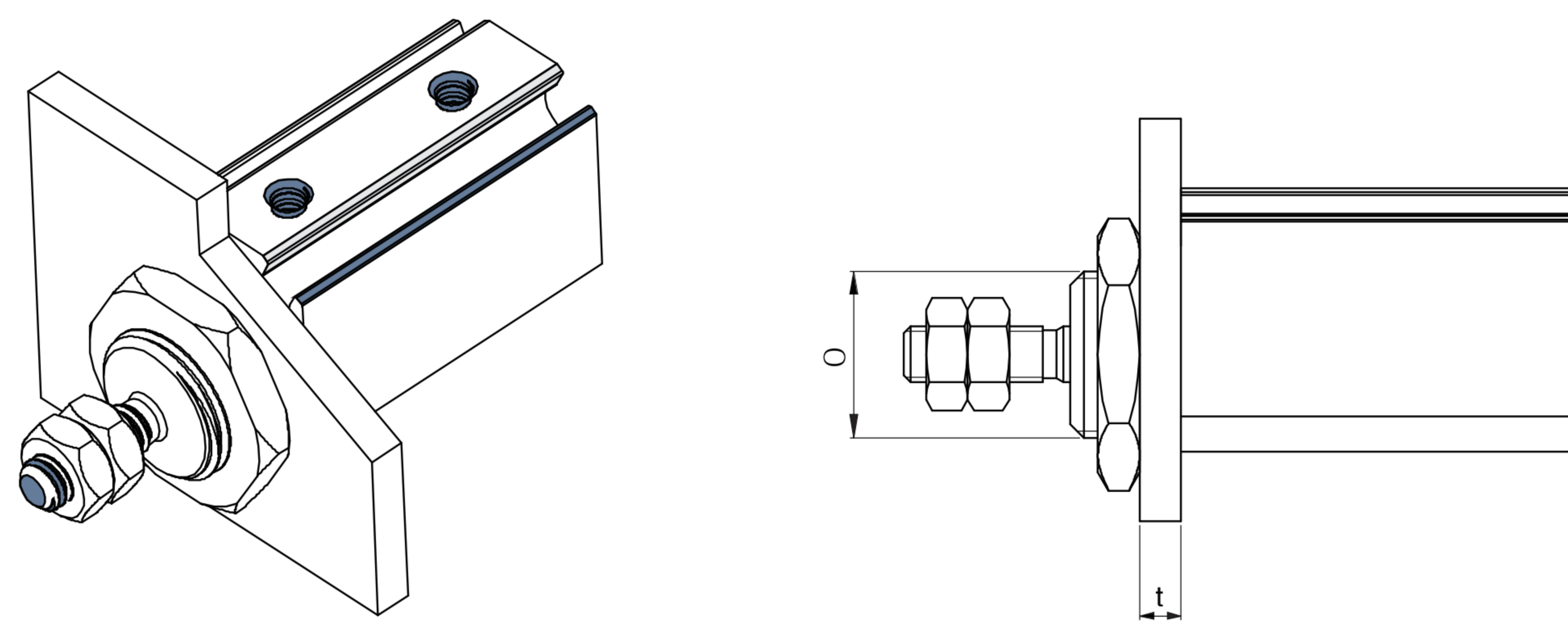

Bore	Thread specification(Ø)	Max. Thickness(t)	Panel hole size
6	M10X1.0	4	Ø10.5
10	M12X1.0	4	Ø12.5
16	M14X1.0	6	Ø14.5