

Accessory

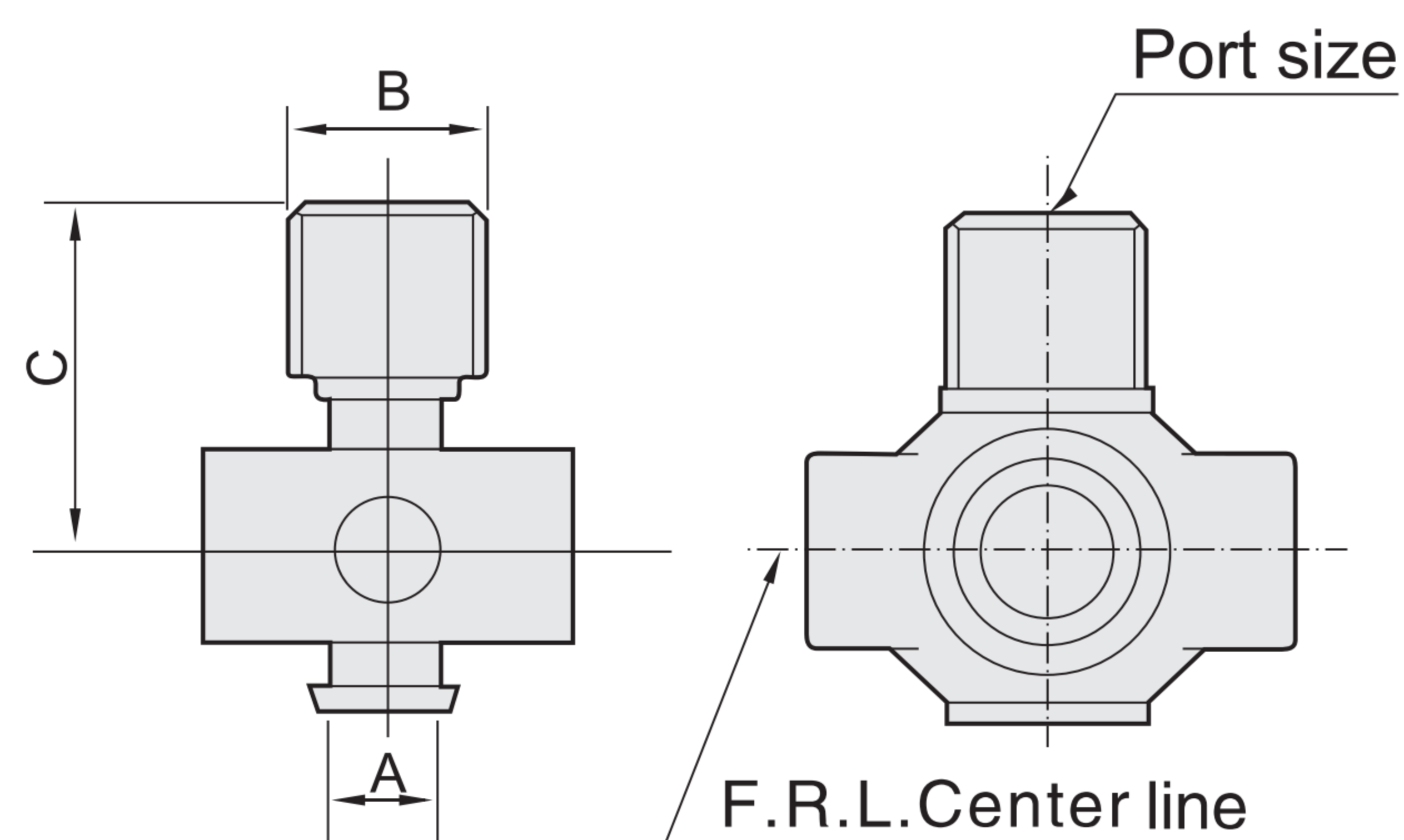

○ T-Type Spacer

Model	*Port Size (G)	A	B	C	Applicable Model
Y21-01	G1/8	10	19	29	EC2000
Y21-02	G1/4				
Y31-01	G1/8	11	19	33	EC3000
Y31-02	G1/4				
Y41-02	G1/4	14	24	39	EC4000
Y41-03	G3/8				
Y61-03	G3/8	15	30	50.5	EC5000
Y61-04	G1/2				

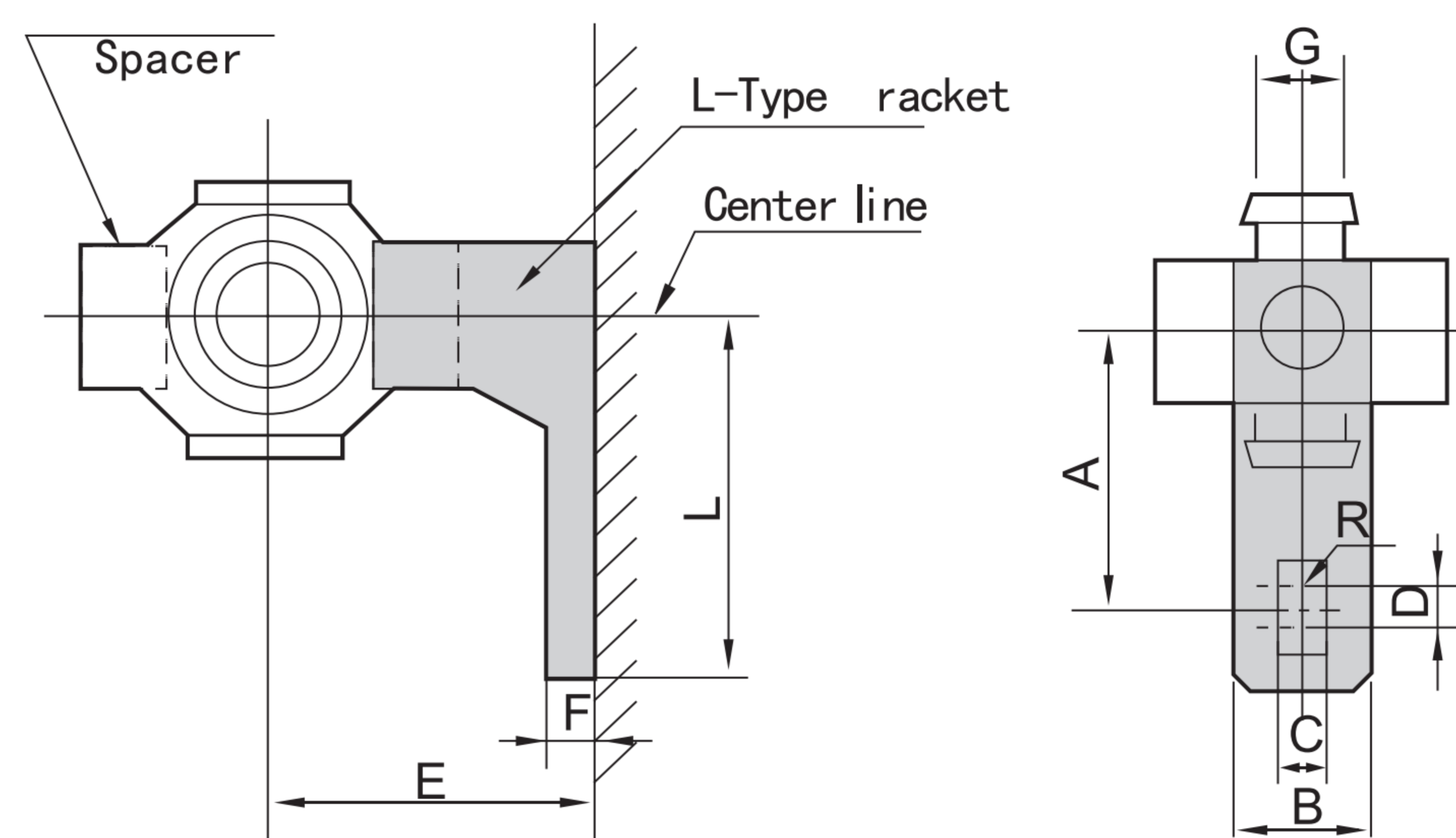
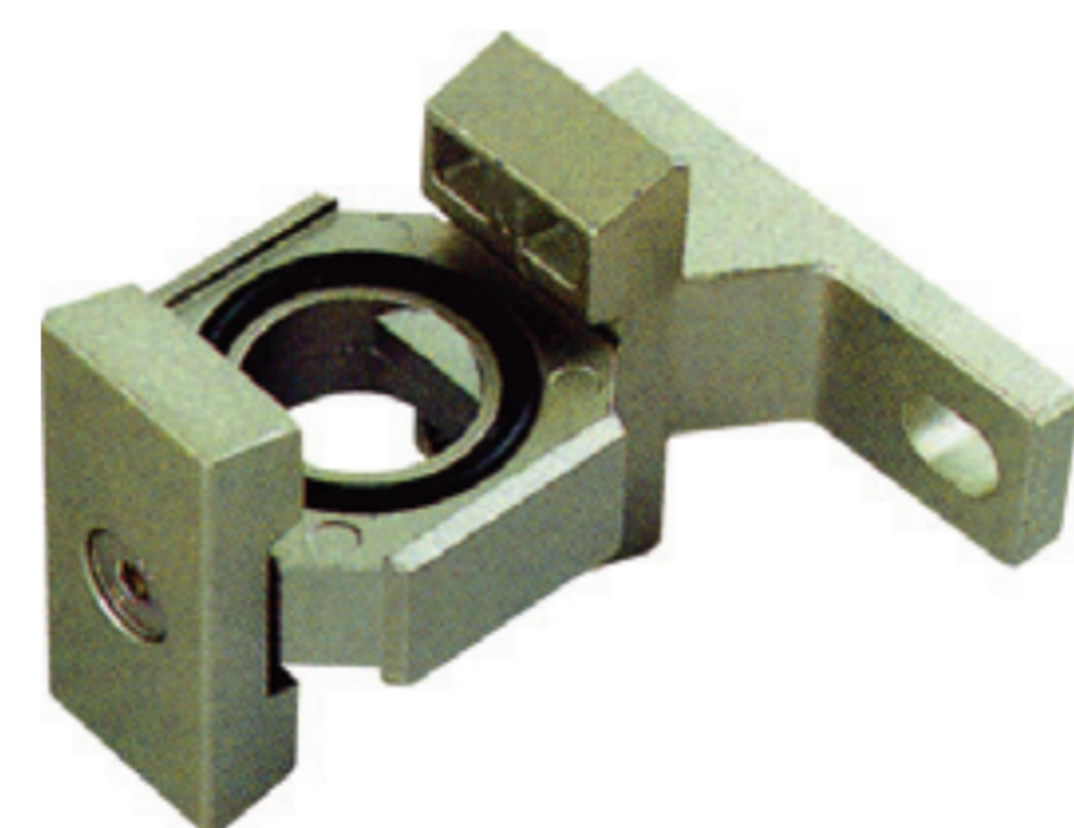
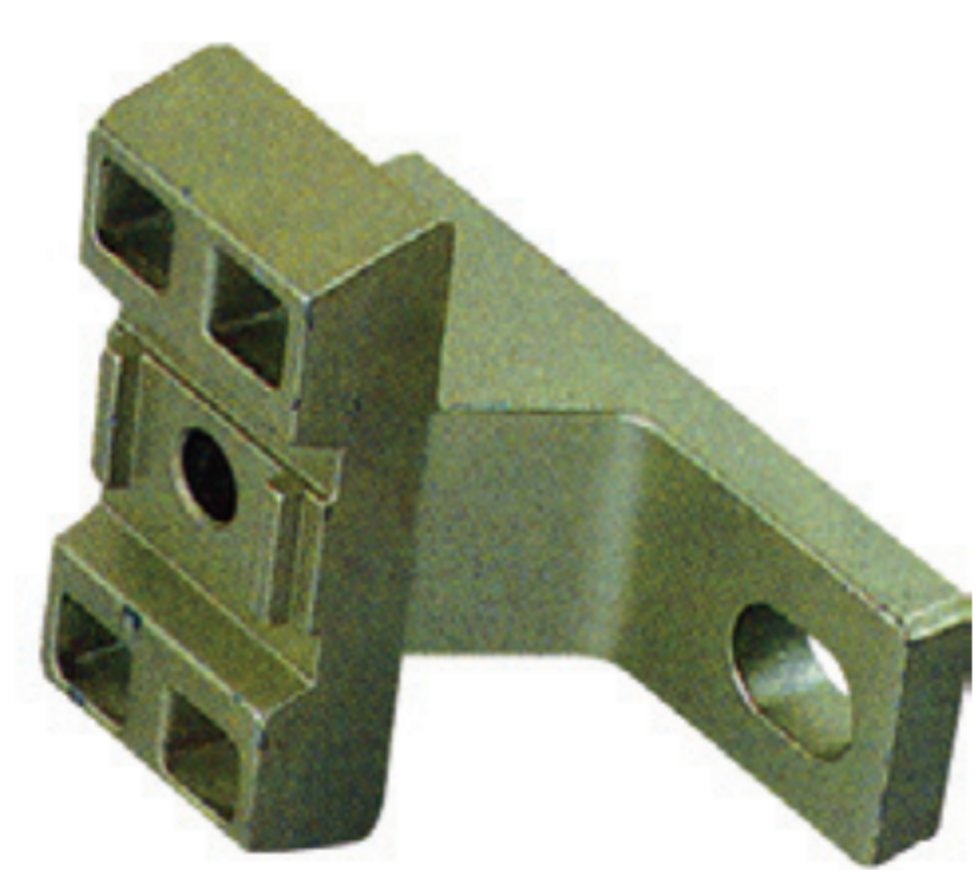

○ L-Type Bracket ○ Spacer with L-Type Bracket

L-Type Bracket	Spacer with L-Type Bracket	A	B	C	D	E	F	G	R	L	Applicable Model
B110L	Y10L	20	12	4.5	3	25	5	8	2.25	27	EC1000
B210L	Y20L	24	15	5.5	3	30	5	10	2.75	33	EC2000
B310L	Y30L	35	16	7	4	41	7	11	3.5	45	EC2500-EC3000
B410L	Y40L	40	22	9	4	50	7	14	4.5	50	EC4000
B510L	Y50L	40	22	9	4	50	7	14	4.5	50	EC4000-06
B610L	Y60L	50	23	12	4	69.8	10.5	15	6	63	EC5000
IB210L	IY20L	24	15	5.5	3	30	5	10	2.75	33	EIC2000
ILB310L	ILY30L	35	16	7	4	41	7	11	3.5	45	Connect EIC3000 filter and regulator
IRB310L	IRY30L	35	16	7	4	41	7	11	3.5	45	Connect EIC3000 regulator and lubricator

*EIC4000/5000 adopts EC series corresponding model.

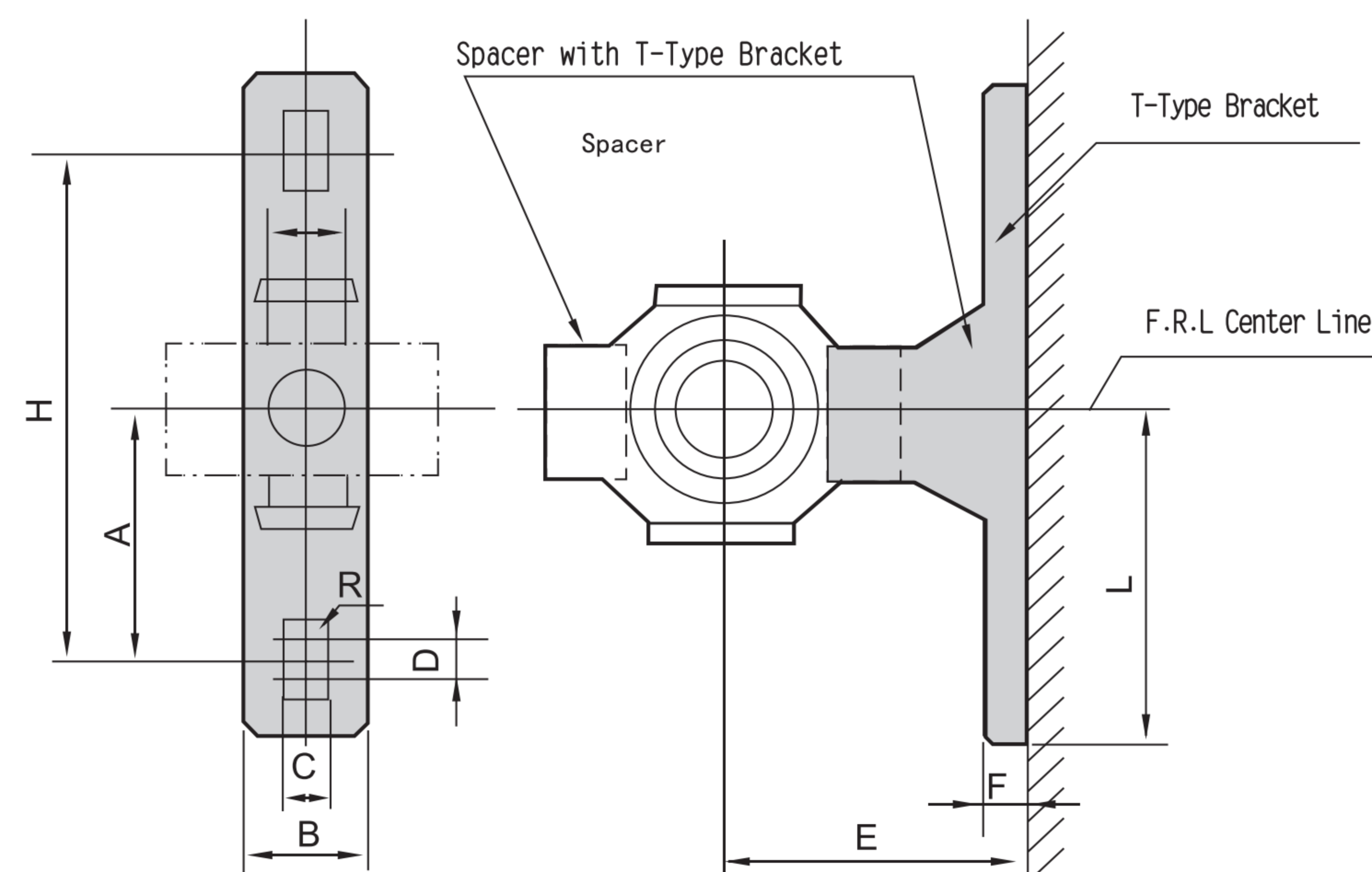
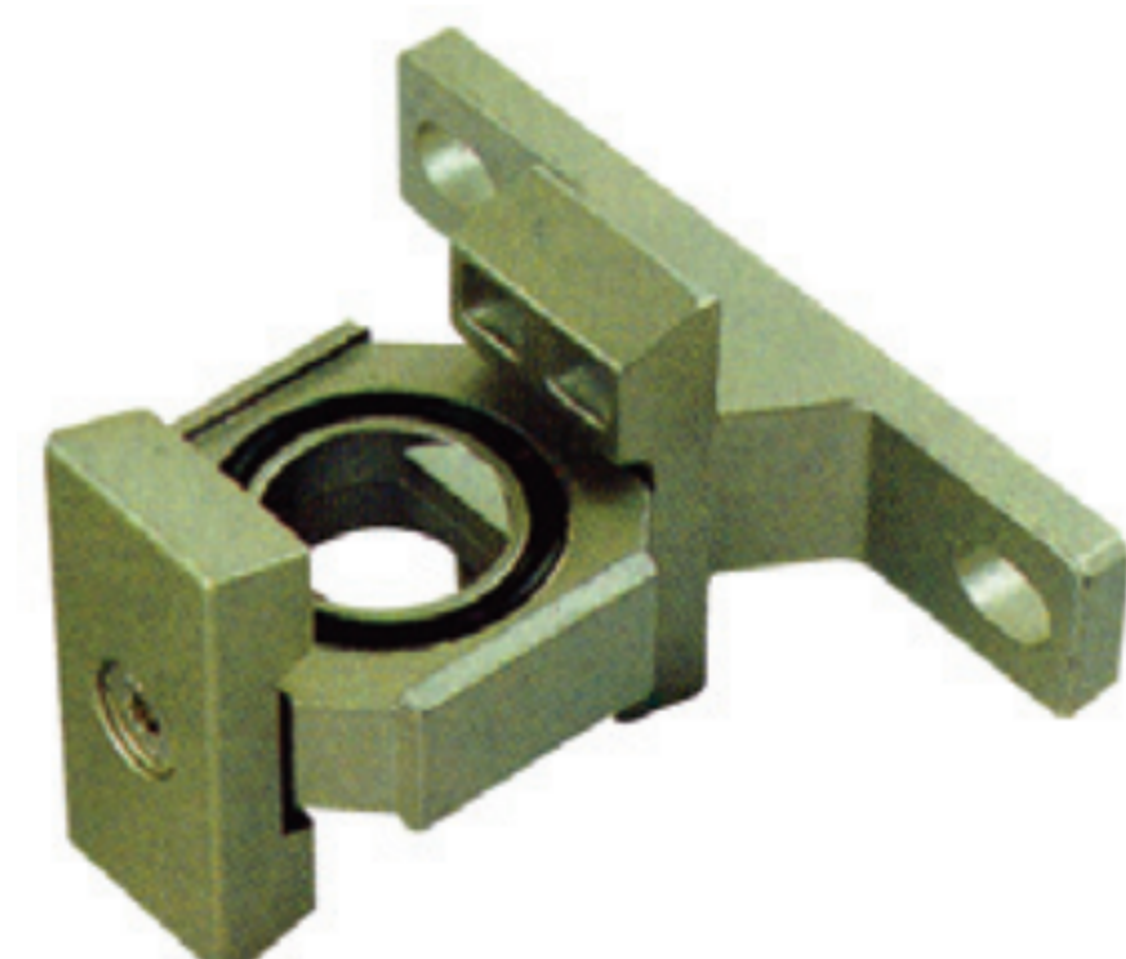
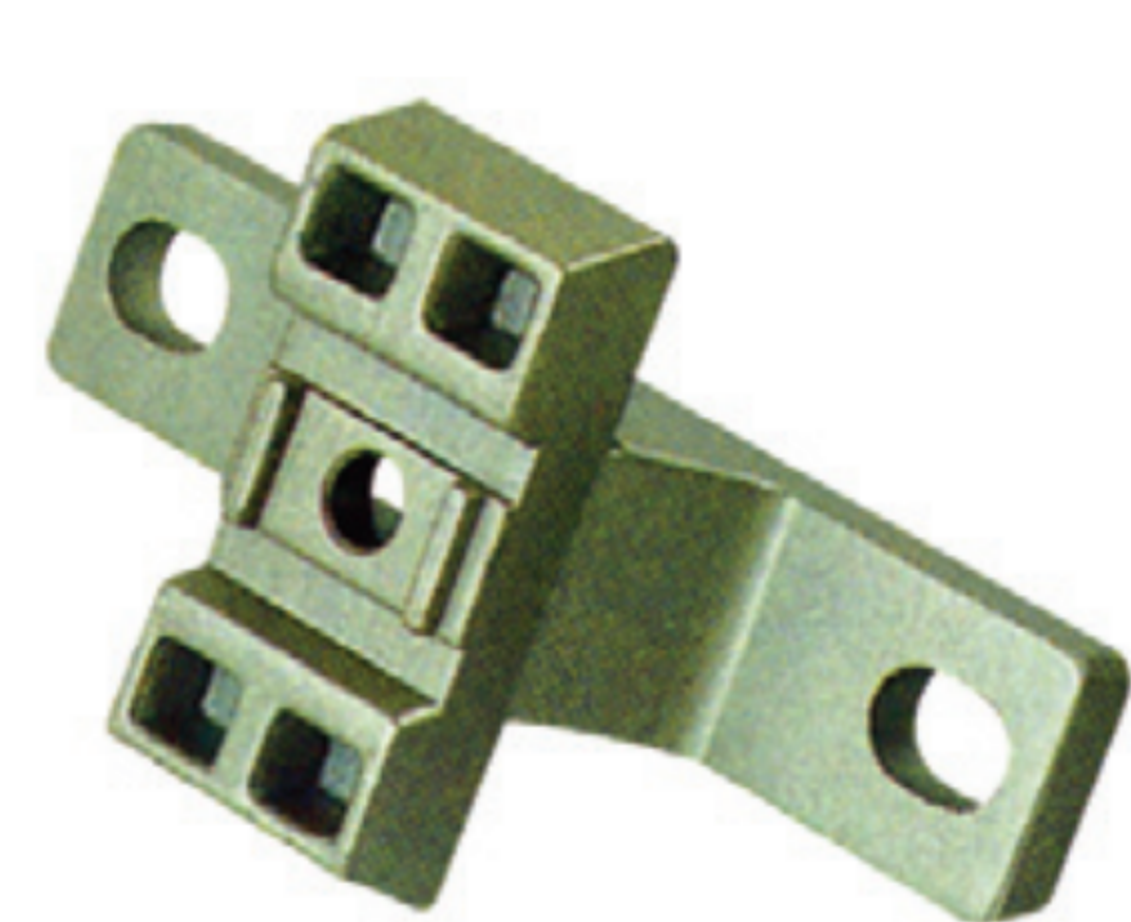

○ T-Type Bracket ○ Spacer with T-Type Bracket

T-Type Bracket	Spacer with T-Type Bracket	A	B	C	D	E	F	G	H	R	L	Applicable Model
B110T	Y10T	20	12	4.5	3	25	5	8	40	2.25	27	EC1010
B210T	Y20T	24	15	5.5	3	30	5	10	48	2.75	33	EC2010
B310T	Y30T	35	16	7	4	41	7	11	70	3.5	45	EC3010
B410T	Y40T	40	22	9	4	50	7	14	80	4.5	50	EC4010
B510T	Y50T	40	22	9	4	50	7	14	80	4.5	50	EC4010-06
B610T	Y60T	50	23	12	4	69.8	10.5	15	100	6	63	EC5010
IB210T	IY20T	24	15	5.5	3	30	5	10	48	2.75	33	EIC2010
IB310T	IY30T	35	16	7	4	41	7	11	70	3.5	45	EIC3010

*EIC4000/5000 adopts EC series corresponding model.

◎ Y-Type Spacer

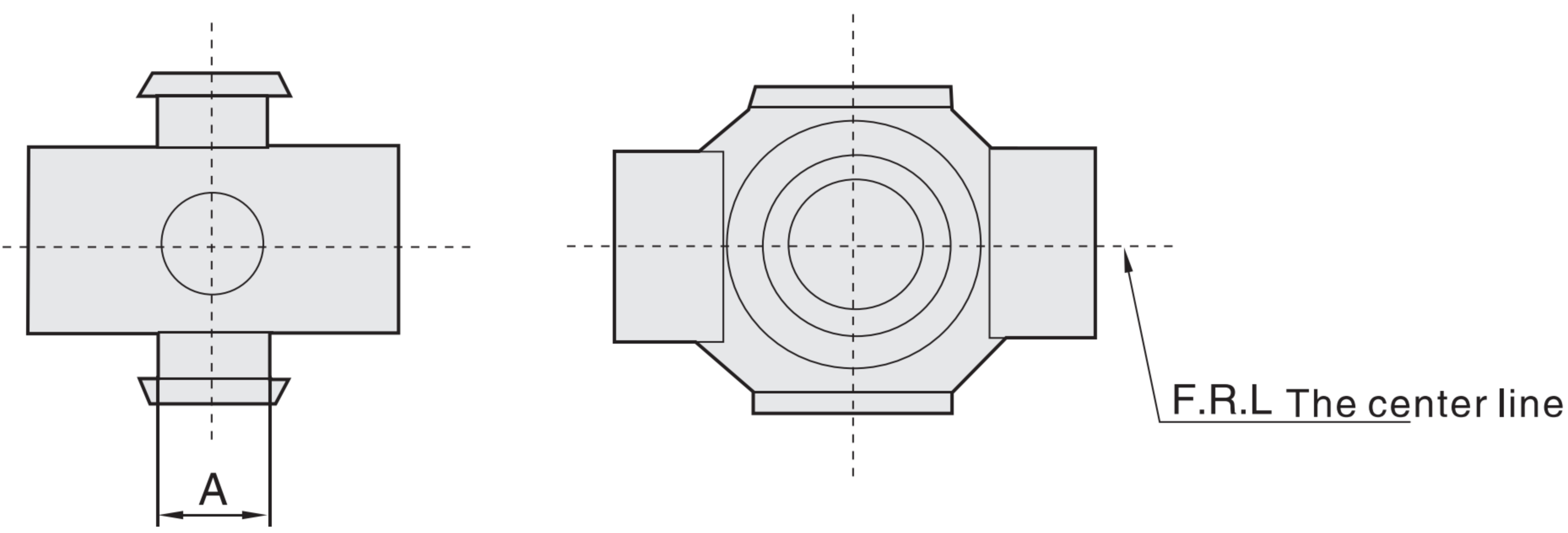

Model	A	Applicable model
Y10	8	EC1000
Y20	10	EC2000
Y30	11	EC2500 - 3000
Y40	14	EC4000
Y50	14	EC4000-06
Y60	15	EC5000

◎ 20-Type Bracket

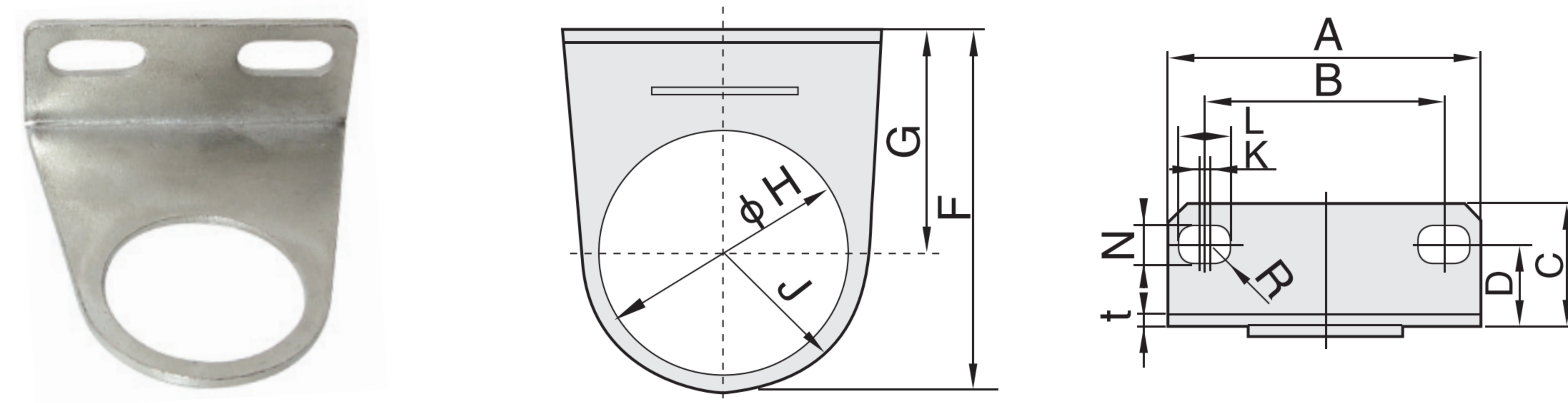

Model	A	B	C	D	F	G	ϕH	J	K	L	N	R	t	Applicable model
B120	40	28	17	11	37.8	25	20	12.3	2	6.5	4.5	2.25	2	ER/EW 1000
B220	55	33.5	24	18	50.5	30.5	33	20	10	15	5.4	2.7	2	ER/EW 2000、ER2500
B320	53	40	22	14	64	39	42	25	1.5	8	6.5	3.25	2	ER/EW 3000
B420	70	53.5	27	18	78.5	48.2	52	30	2	10.5	8.5	4.25	2	ER4000~5000 EW4000~5000

◎ 40-Type Bracket

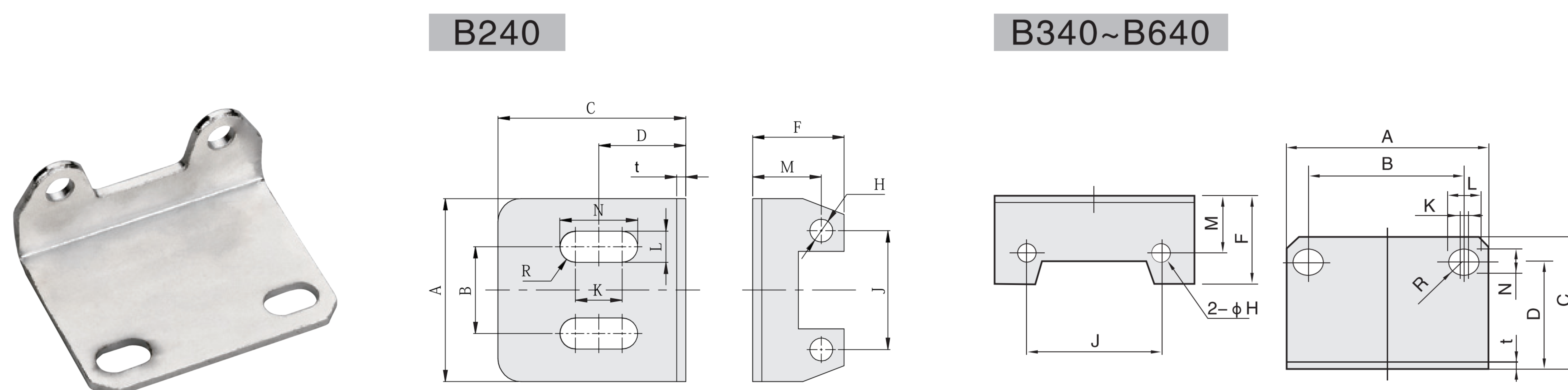

Model	A	B	C	D	F	ϕH	J	K	L	M	N	R	t	Fixing screw	Applicable model
B240	40	19	41	19	20	5	26	10.2	6.8	15	17	3.4	2	M4x8	EF/EL2000
B340	53	40	38	31.2	23	4.5	35	1.5	8	19	6.5	3.25	2	M4x8	EF/EL3000
B440	70	54	49	40	30	5.5	47	2	10.5	18.4	8.5	4.25	2	M5X12	EF/EL4000
B540	70	54	49	40	30	5.5	47	2	10.5	21.5	8.5	4.25	2	M5X12	EF/EL4000-06
B640	90	66	64	52	43	6.5	60	2	13	29	11	5.5	2	M5X12	EF/EL5000