

EF Series Air Preparation Unit

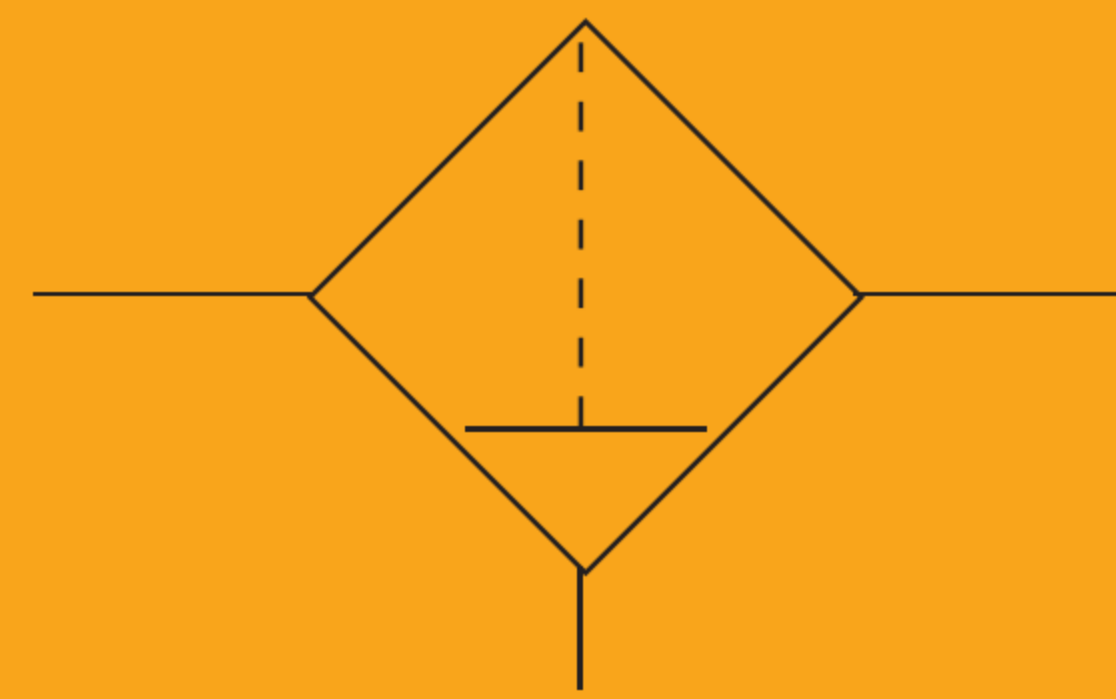

EF Filter



Specifications

Model	EF1000	EF2000	EF3000	EF4000	EF5000
Proof pressure(MPa)	1.5				
Max. working pressure(MPa)	1.0				
Working temperature(°C)	-5~60 (No freezing)				
Filter precision	25 μm (5 μm is optional)				
Bowl material	Polycarbonate				
Bowl guard	None		Available		
Pressure adjusting range (MPa)	0.15~1.0				

Model	Specifications				Accessories	Drain function	Auto drain model
	*Rated flow (L/min)	** Port size (G)	Bowl capacity (CM ³)	Weight (kg)	Bracket		
EF1000-M5	110	M5	4	0.07	-	Manual drain	EF2000-01D
EF2000-01	1222	1/8	15	0.19	B240		EF2000-02D
EF2000-02	1278	1/4					
EF3000-02	2006	1/4	20	0.29	B340	a. Zero pressure drain	EF3000-02D
EF3000-03	2148	3/8					
EF4000-03	5120	3/8	45	0.55	B440	b. Manual drain	EF4000-03D
EF4000-04	5430	1/2					
EF4000-06	7680	3/4	45	0.58	B540	EF4000-04D	
EF5000-06	8200	3/4					
EF5000-10	8500	1	130	1.08	B640	EF5000-06D	
							EF5000-10D

* The above information is based on 6.3 Bar supply pressure and 1.0 Bar set pressure * NPT,PT port size is optional

Main Dimension

EF1000-EF2000

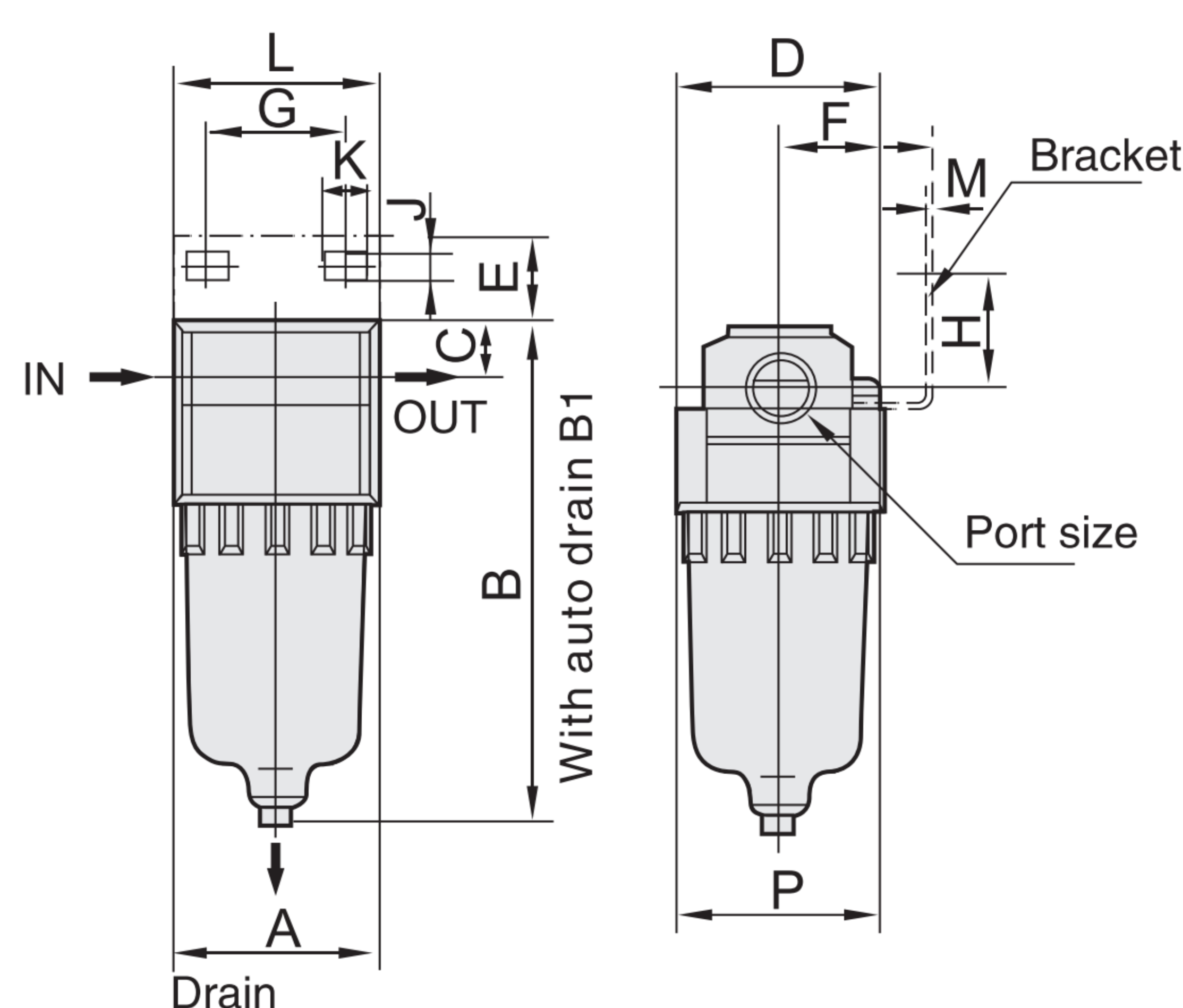

EF3000-EF4000

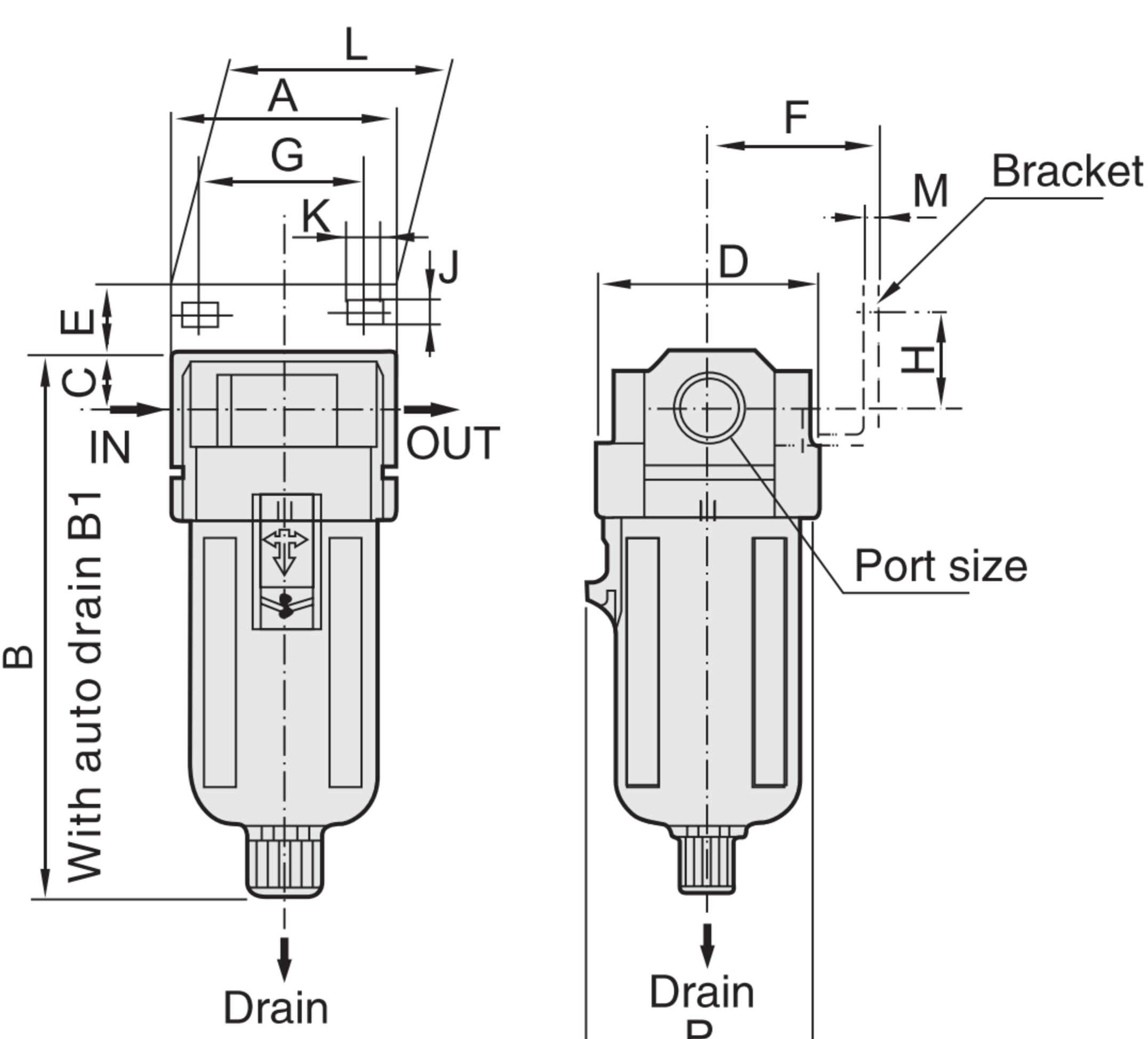

EF5000

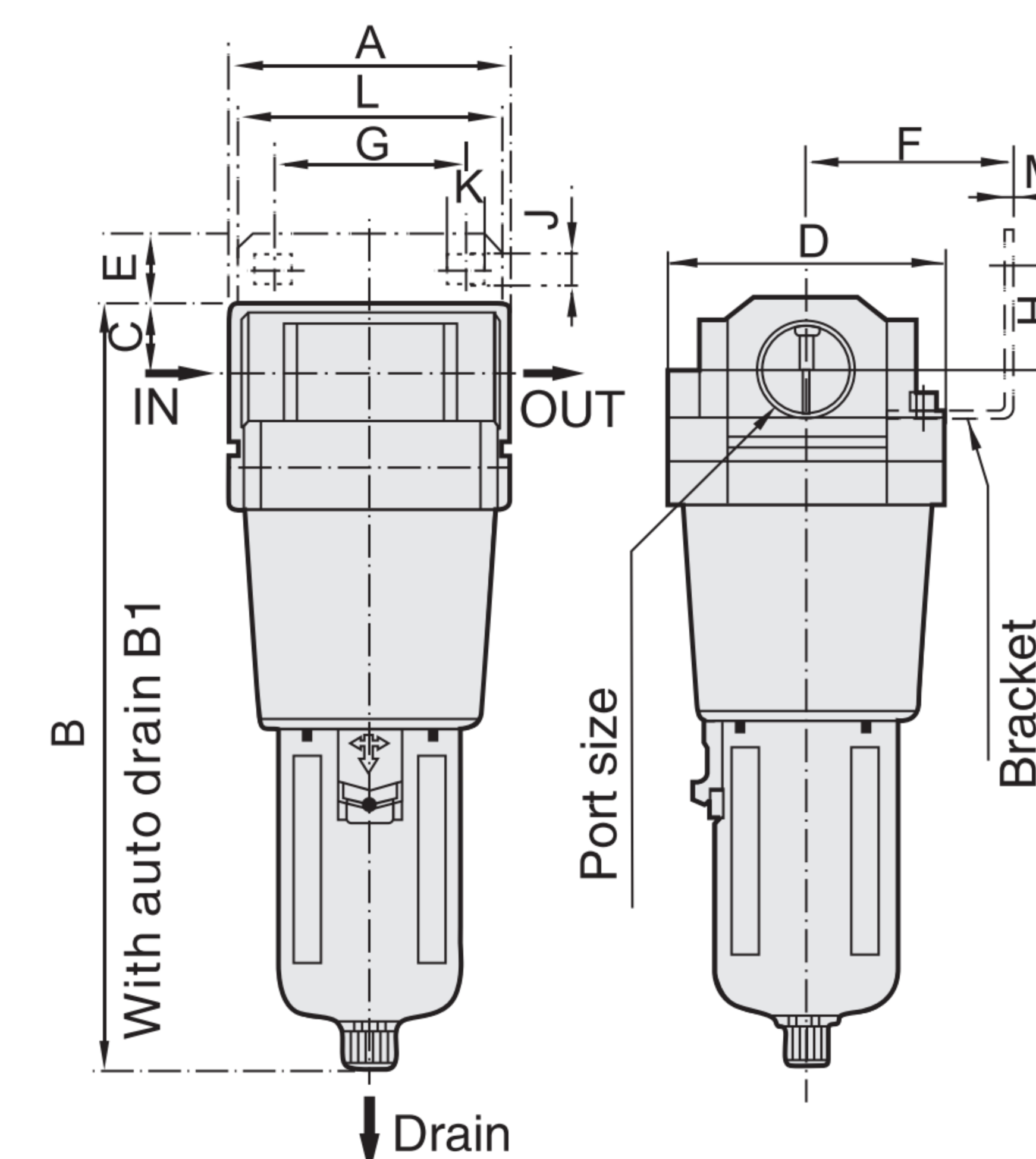

Model	Port Size (G)	A	B	B1	C	D	E	F	G	H	J	K	L	M	P
EF1000	M5	25	66	-	7	25	-	-	-	-	-	-	-	-	26.5
EF2000	1/8"-1/4"	40	96.5	134.5	11	40	25	31	19	14	17	6.8	40	2	40
EF3000	1/4"-3/8"	53	132.5	145	14	53	15	41.5	40	22	6.5	8	53	2	56
EF4000	3/8"-1/2"	70	168	171.5	18	70	18	53	54	27	8.5	10.5	70	2	73
EF4000-06	3/4"	75	172.5	175.5	20	70	14	50	54	25	8.5	10.5	70	2	73
EF5000	3/4"-1"	90	246	250	24	90	23	67	66	35	11	13	90	3	90