

## SZP

### Heavy Duty



#### How to Order?

Series No.	Pad Diameter	Pad Model	Pad Material
SZP: SZP Series	40: Ø40	H: Heavy Duty Model	N: NBR
	50: Ø50	HB: Heavy Duty Bellows Type	S: Silicone Rubber
	63: Ø63		
	80: Ø80		
	100: Ø100		
	125: Ø125		

**Order Example:** SZPY series heavy duty series vacuum pad, pad diameter  $\phi$ 40, heavy duty model, NBR. ERP code is SZP40HN



#### How to Order?

Series No. — Pad Diameter	Pad Model	Pad Material
SZP2: SZP2 Series	32: Ø32	N: NBR S: Silicone Rubber
	150: Ø150	
	250: Ø250	
	300: Ø300	
	340: Ø340	

Code	Pad Model	Pad Diameter				
		Ø32	Ø150	Ø250	Ø300	Ø340
H	Flat Type with ribs	•	•	•	•	•
HB	Bellows Type	•	•			

**Order Example:** SZPY series heavy duty series vacuum pad, pad diameter  $\phi$  32, flat type with ribs, NBR. ERP code is SZP2-32HN

#### Main Dimension

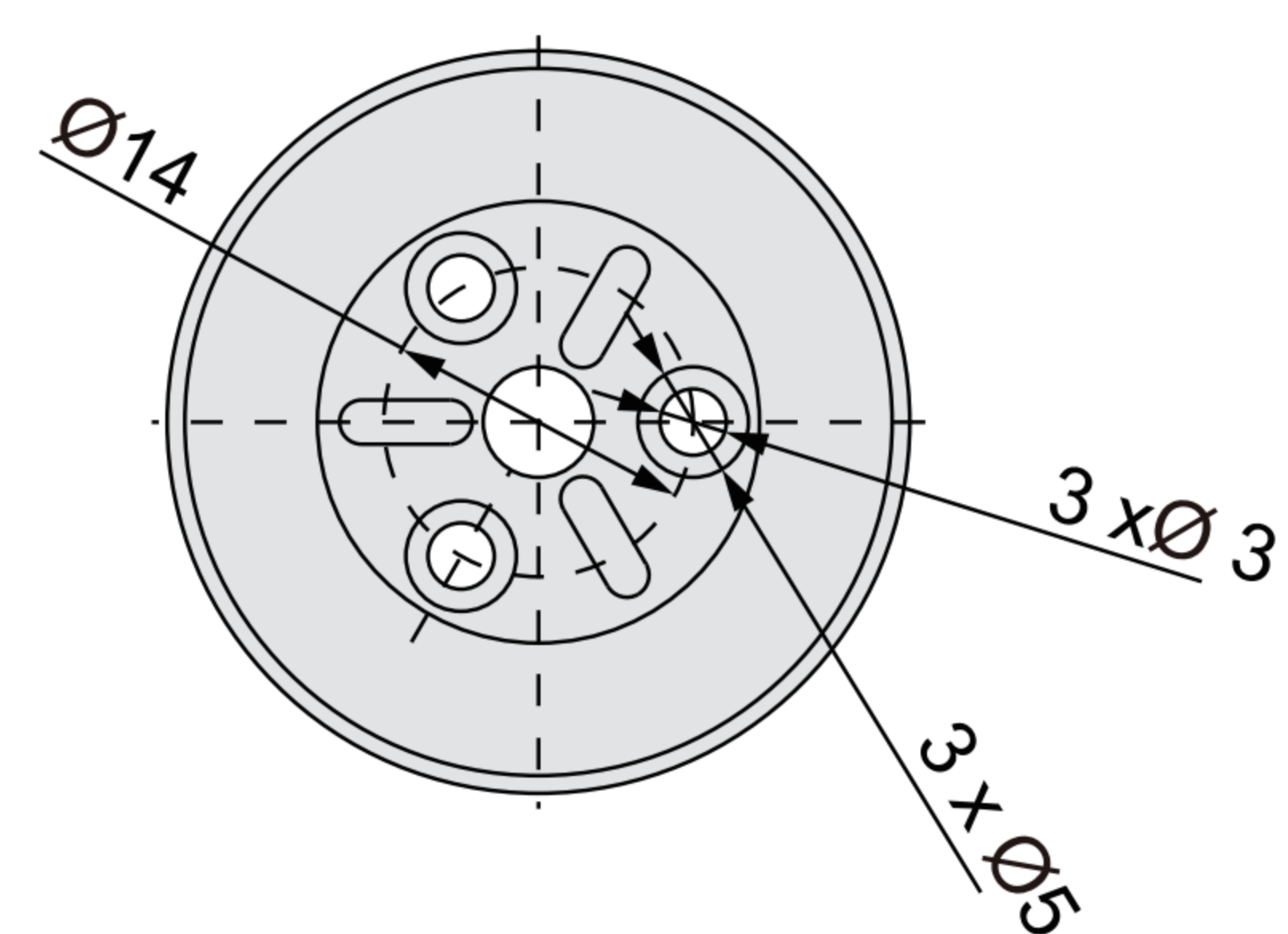
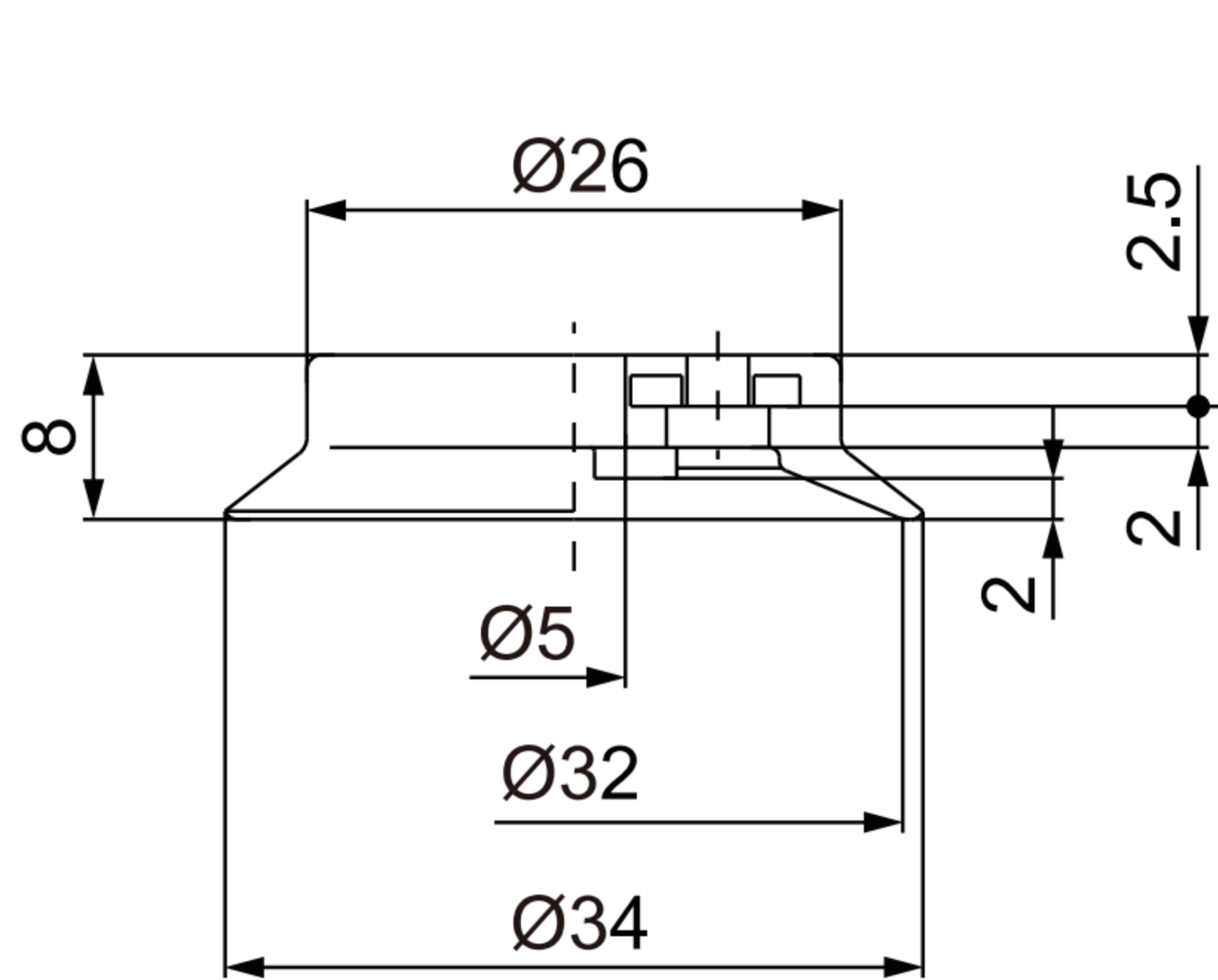

SZP32H□

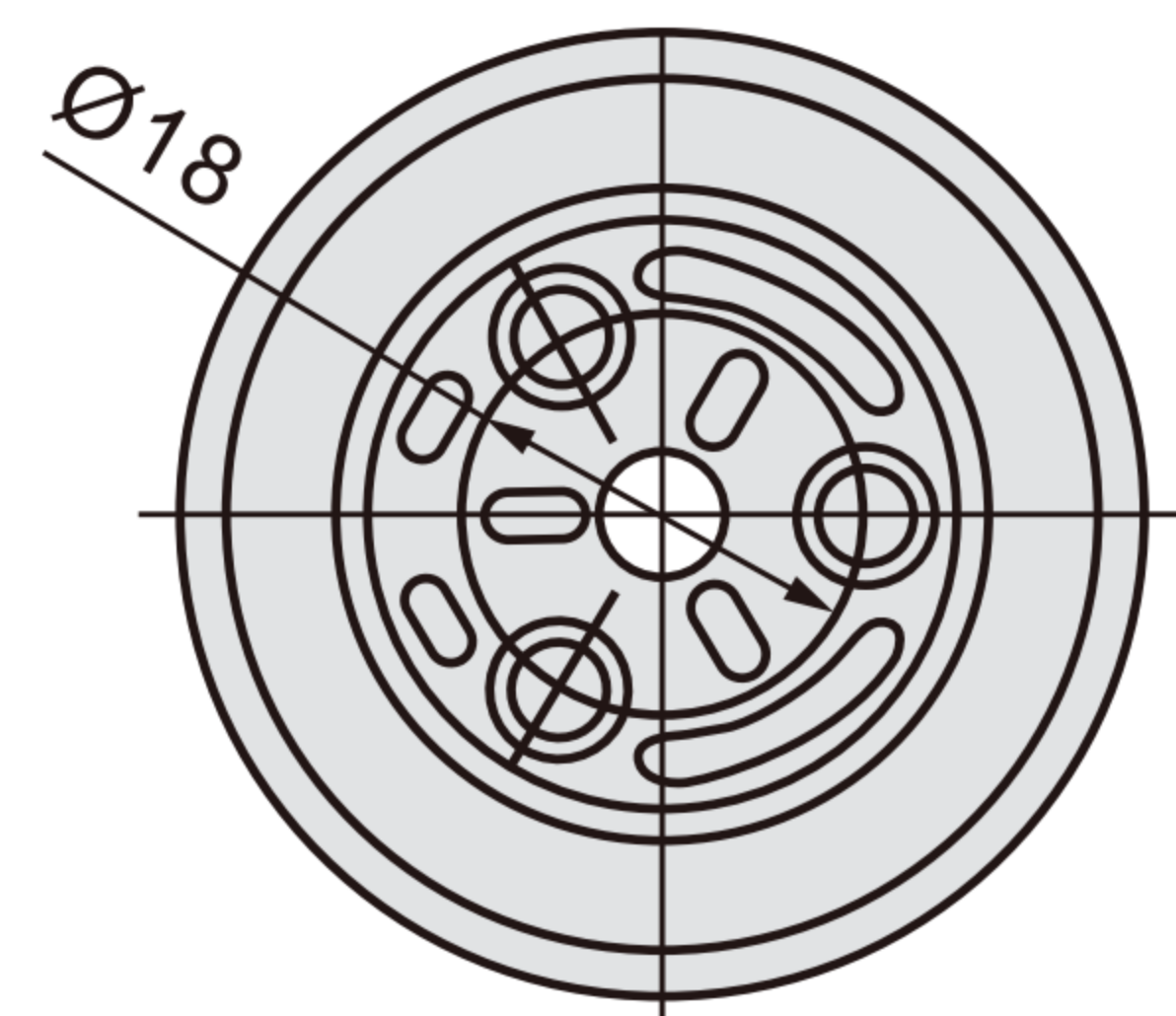
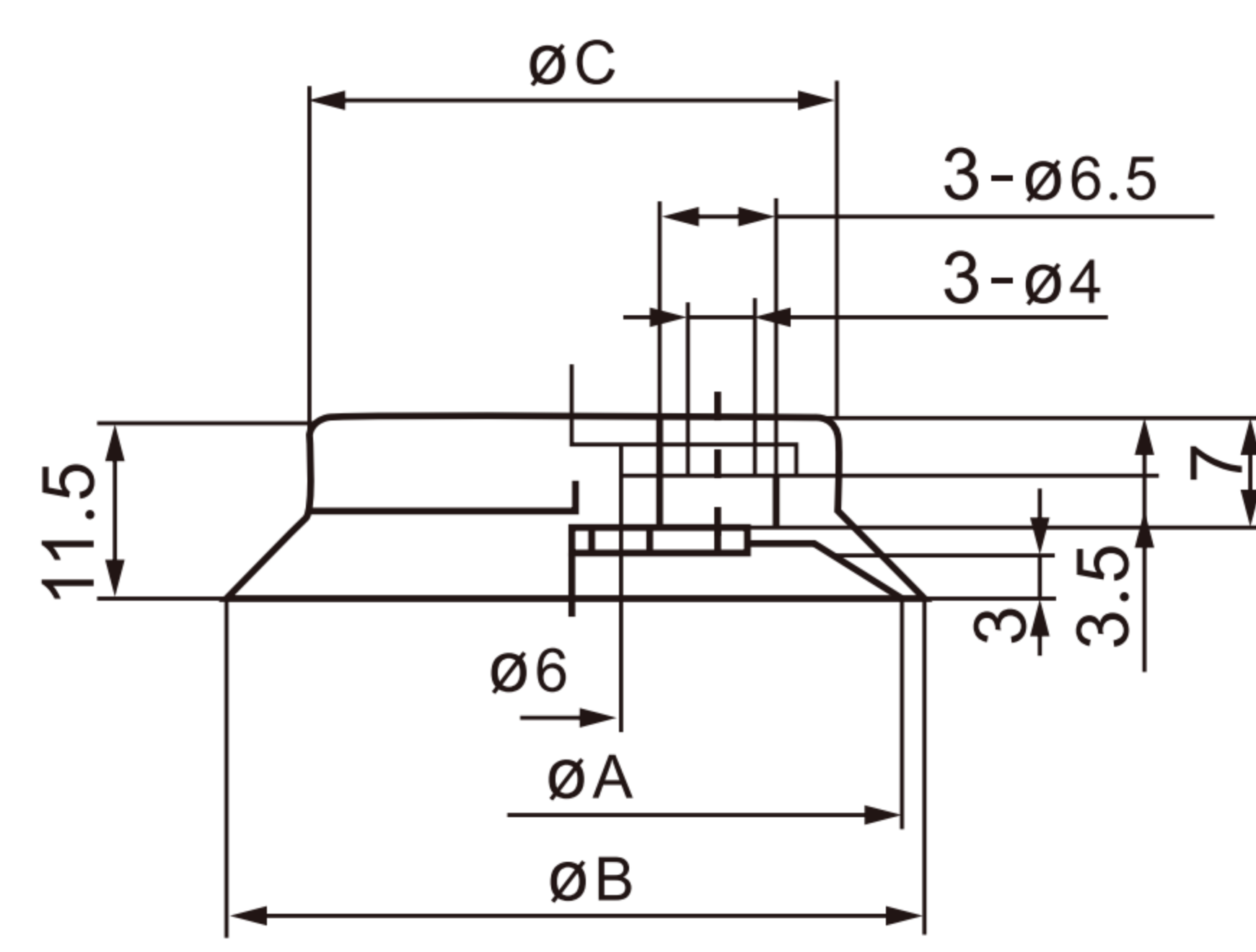

Model	ØA	ØB	ØC
SZP40H□	40	42	32
SZP50H□	50	52	42

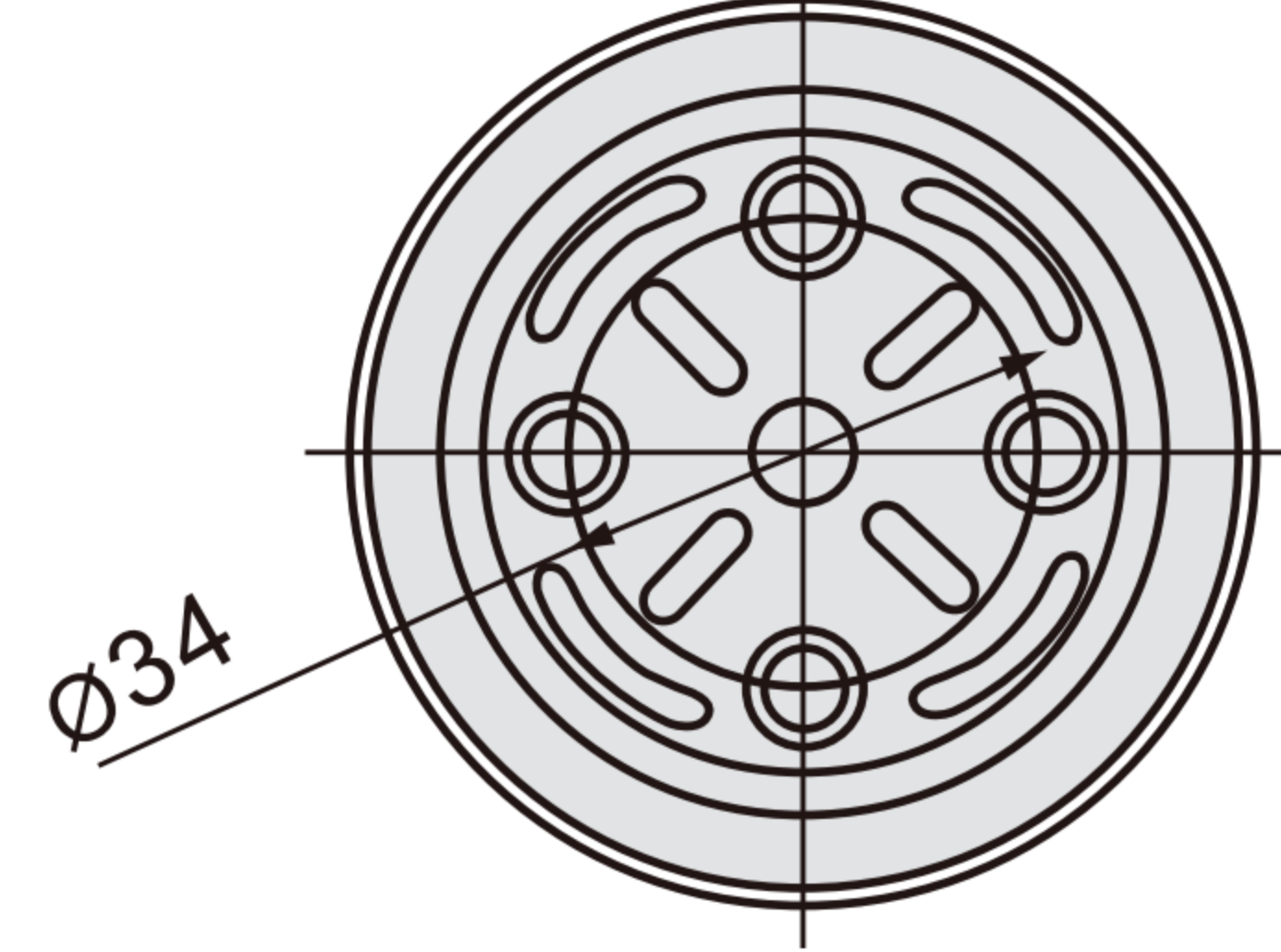
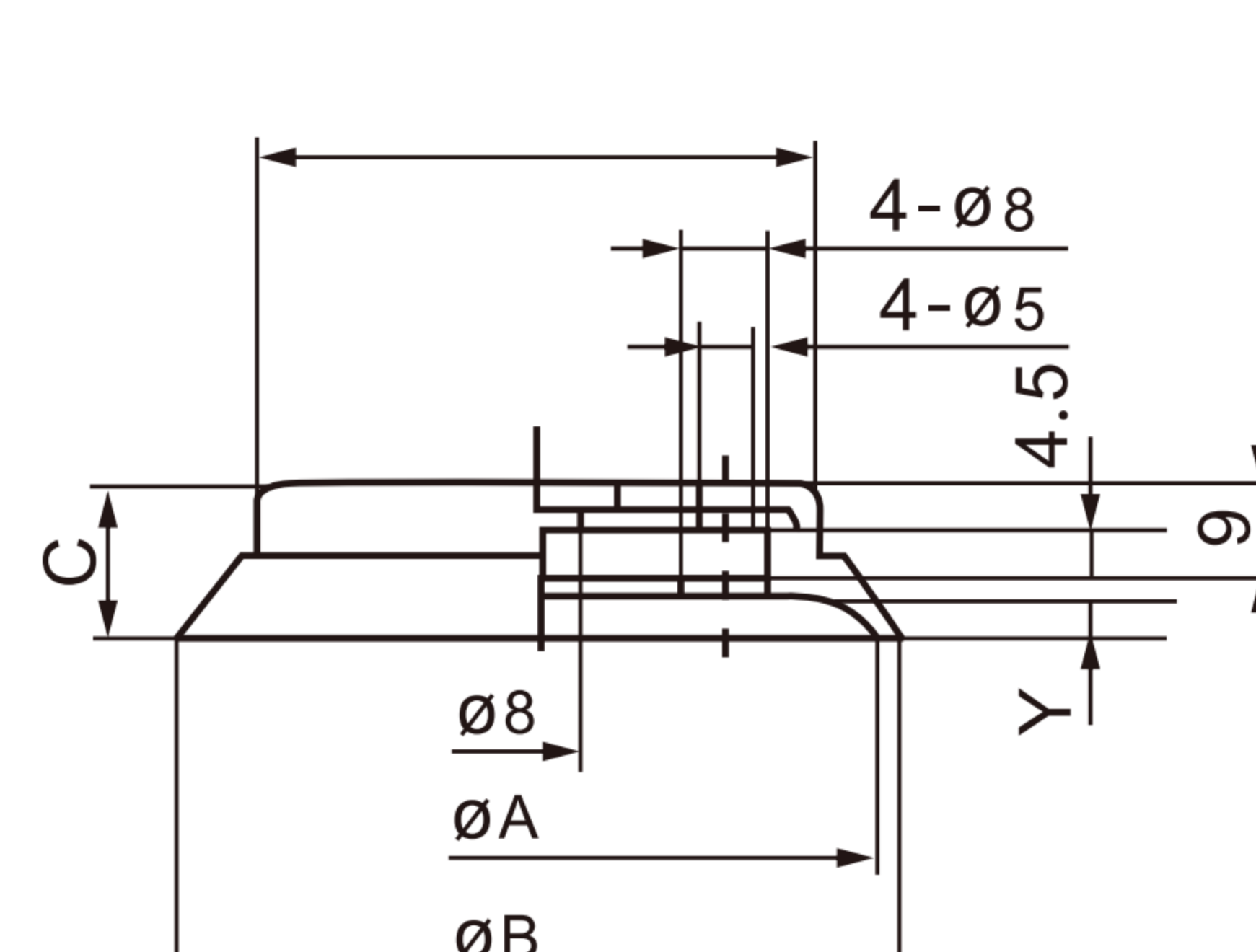

Model	ØA	ØB	C	D	Y
SZP63H□	63	65	14.5	54	3.5
SZP80H□	80	82	16.5	68	4.5

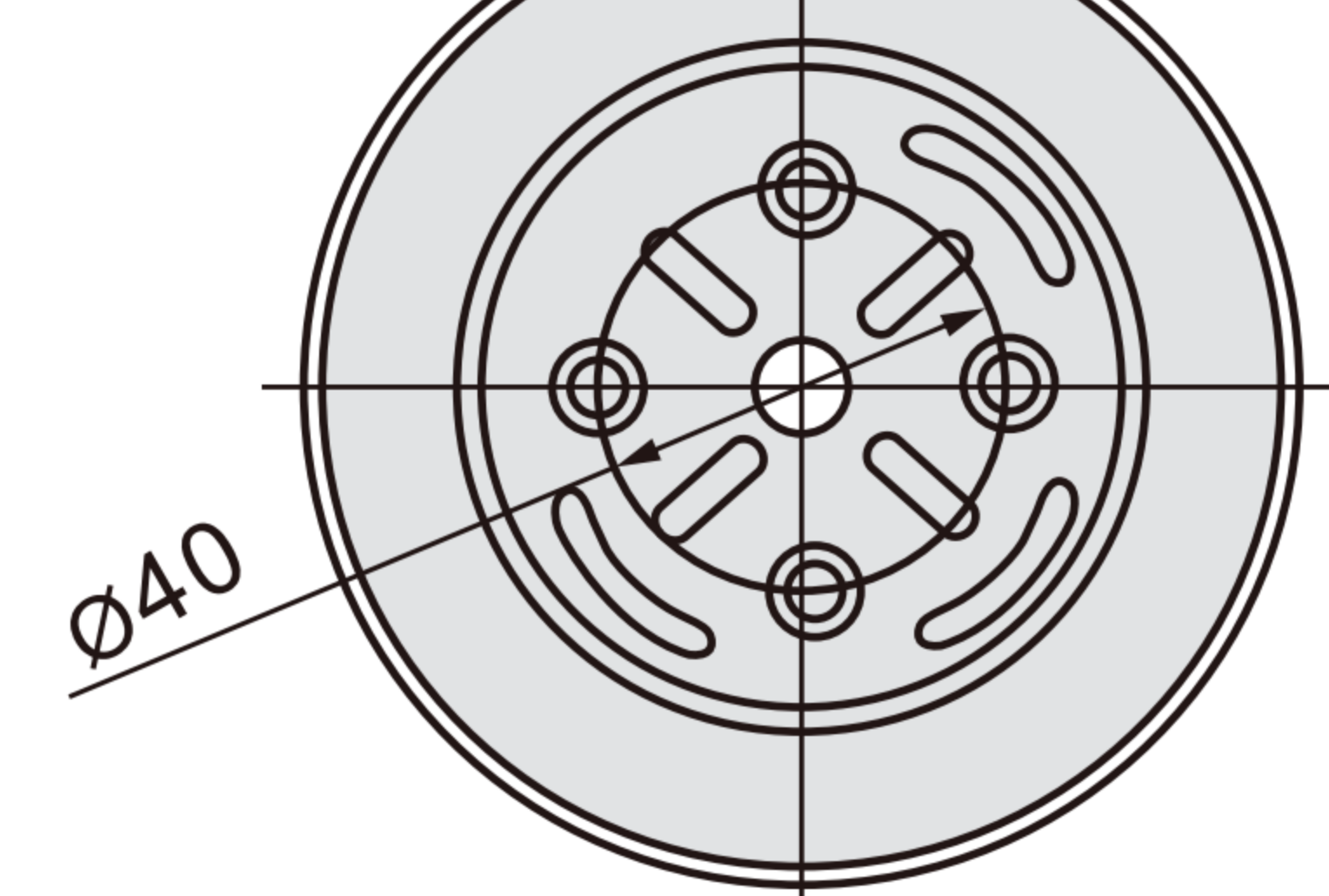
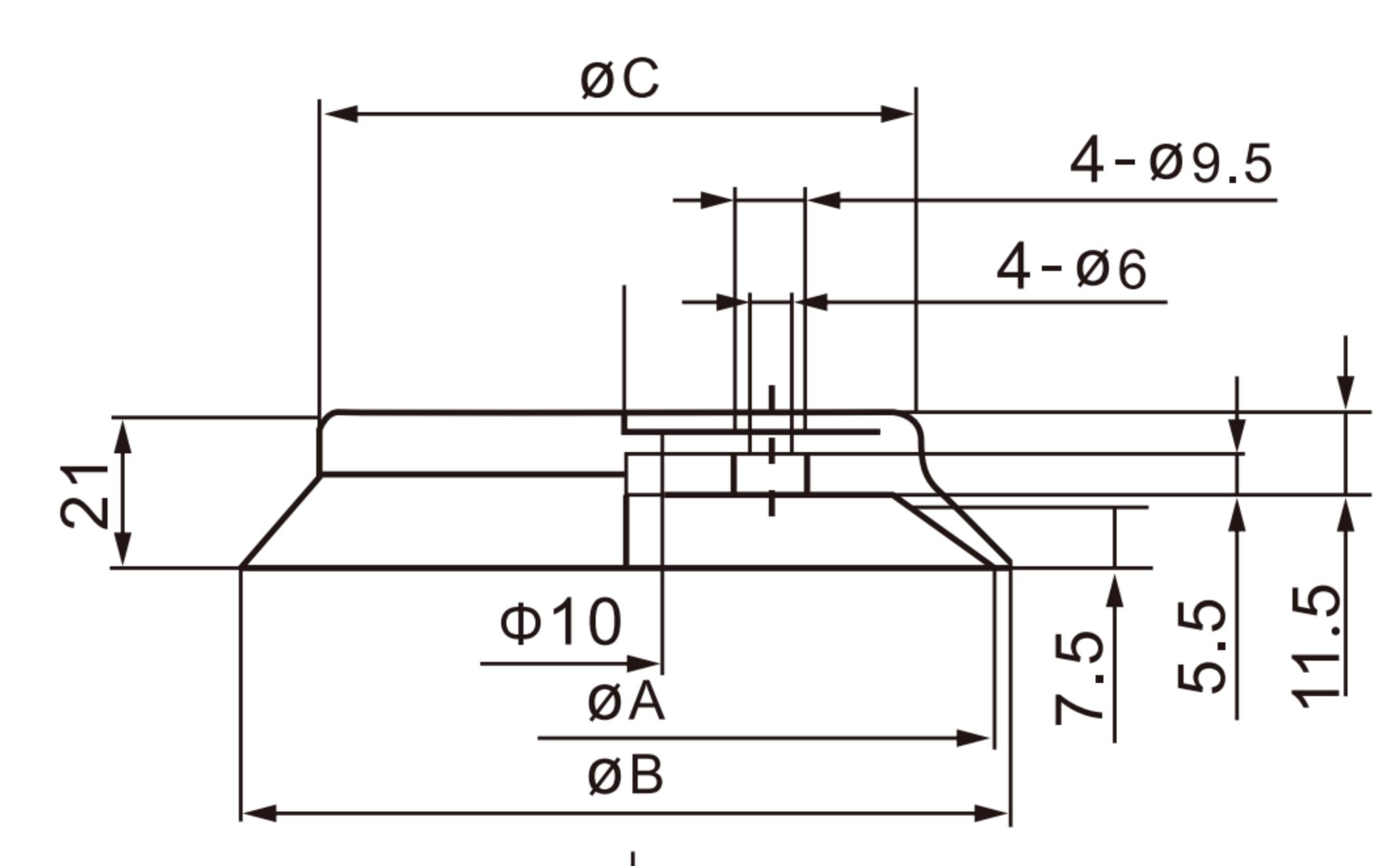

Model	ØA	ØB	ØC
SZP100H□	100	103	80
SZP125H□	125	128	104



# SZP Heavy Duty series



## Main Dimension

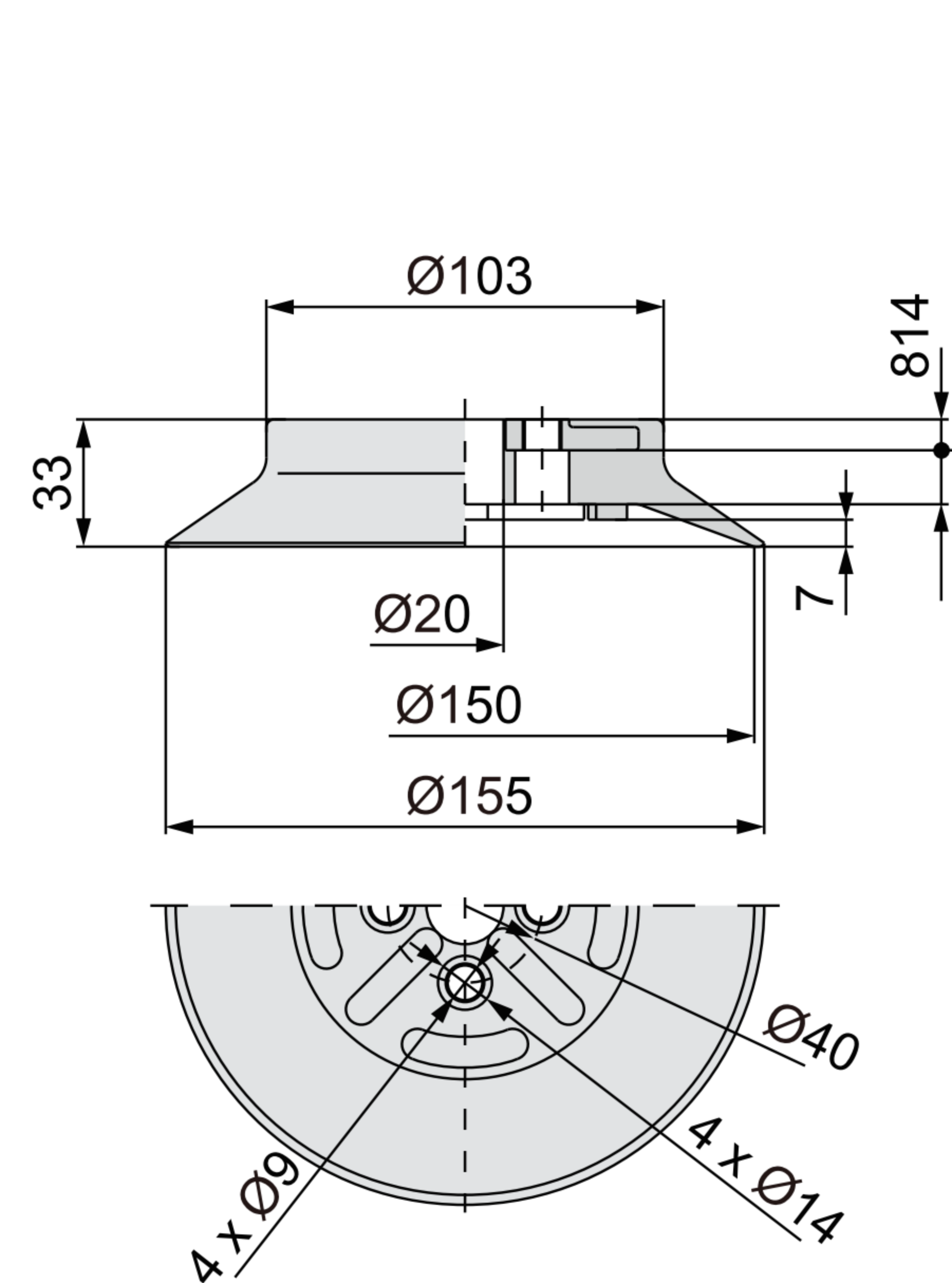

SZP2-150H□

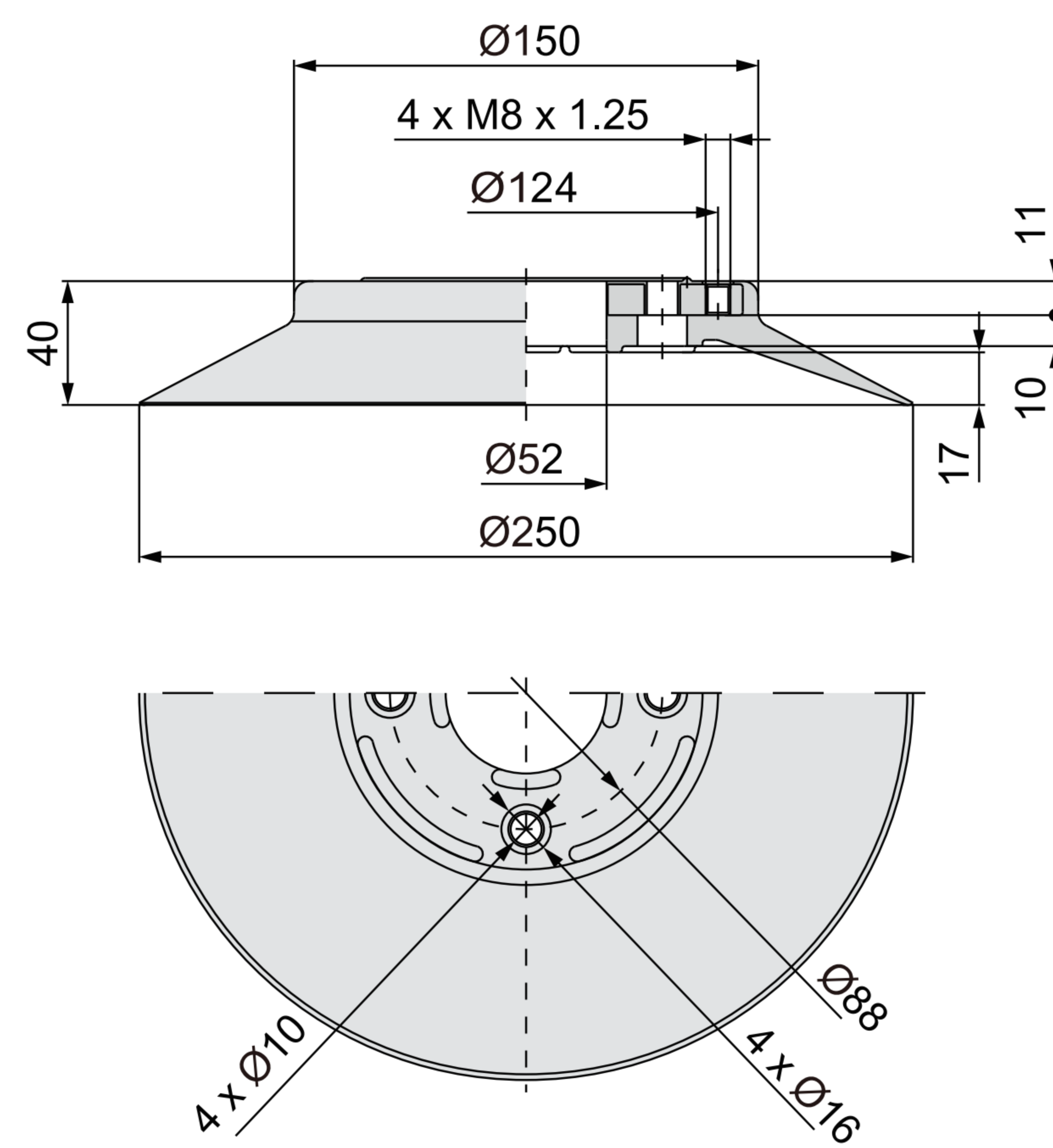

SZP2-250H□

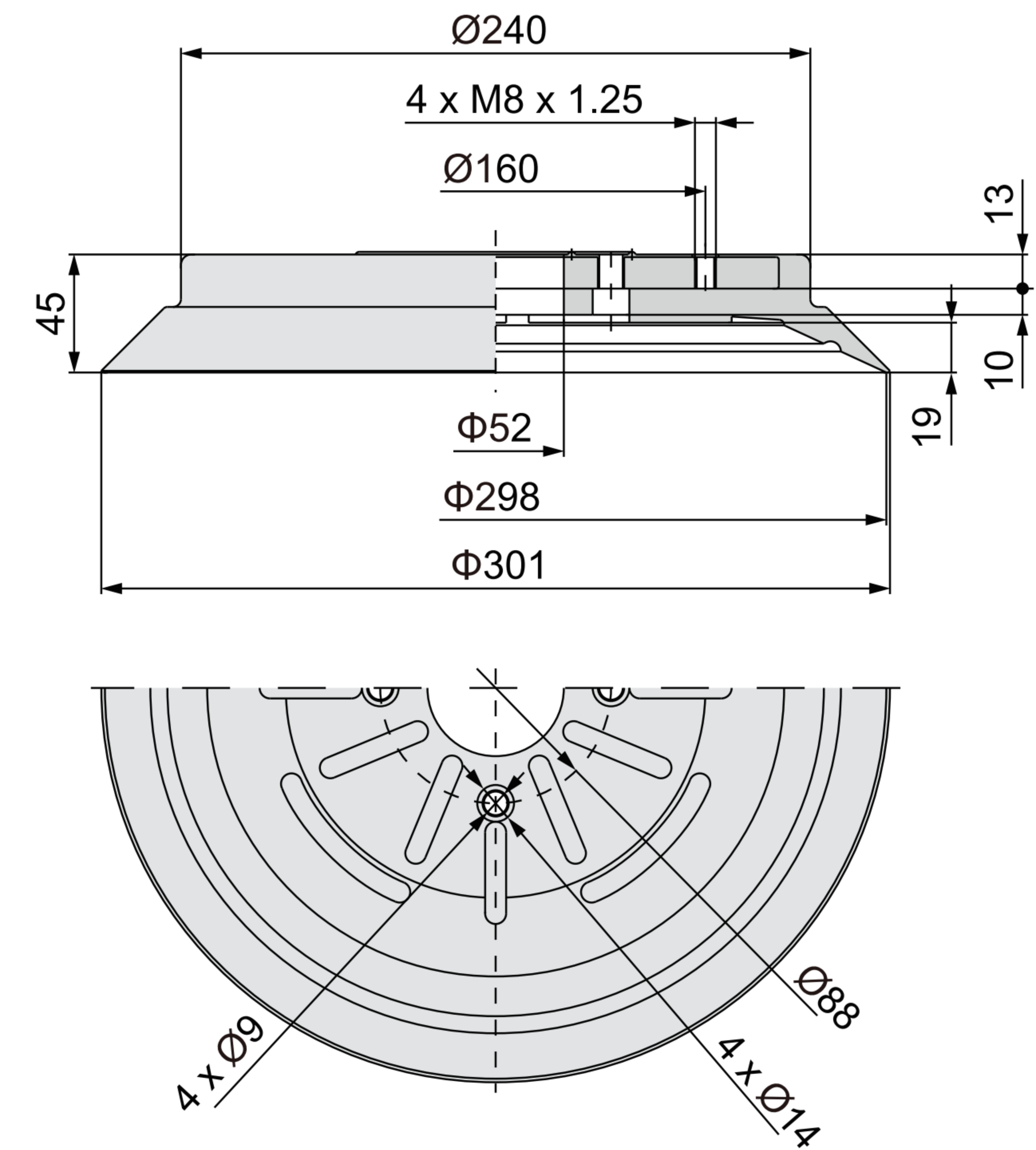

SZP2-300H□

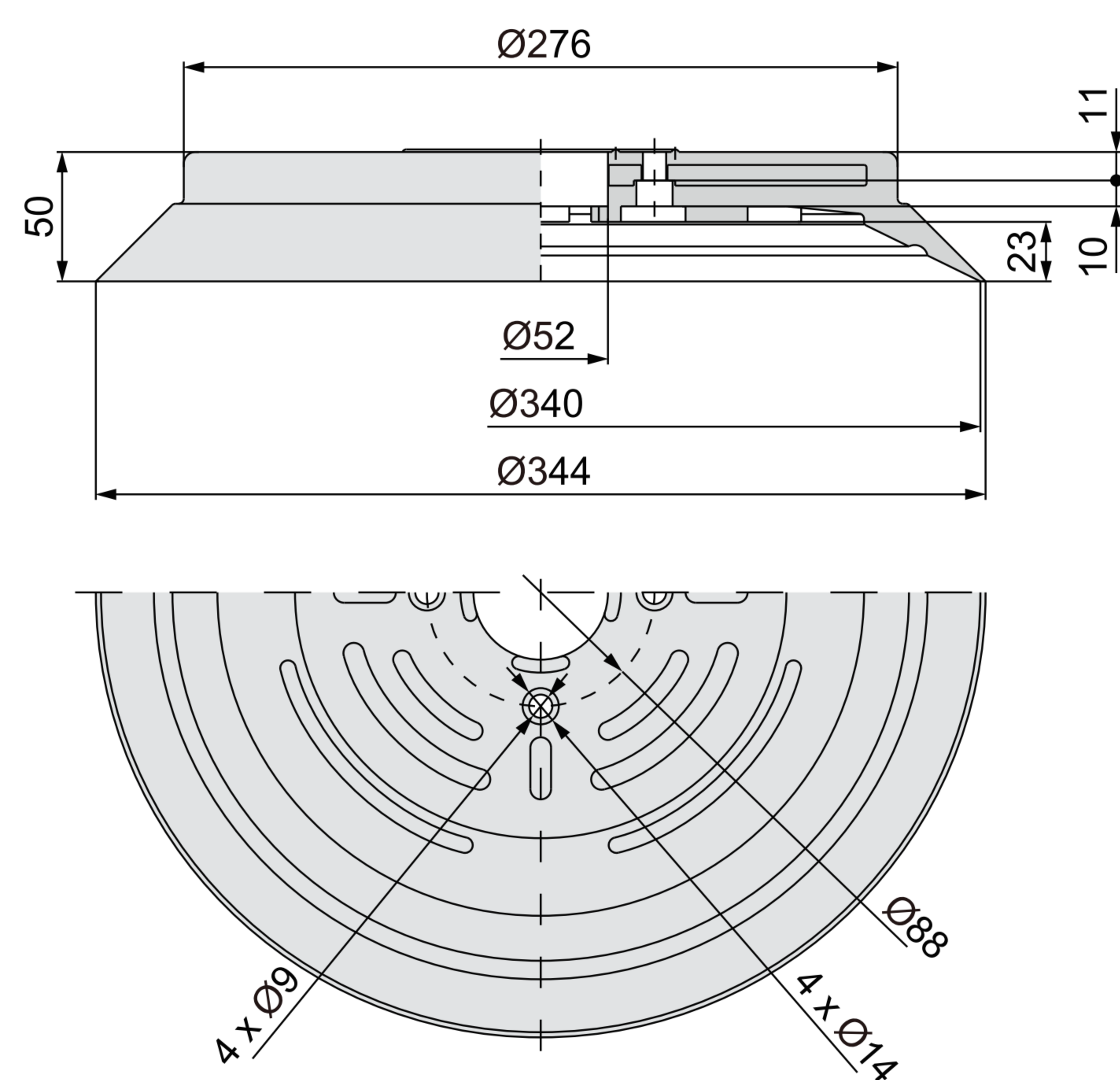

SZP2-340H□

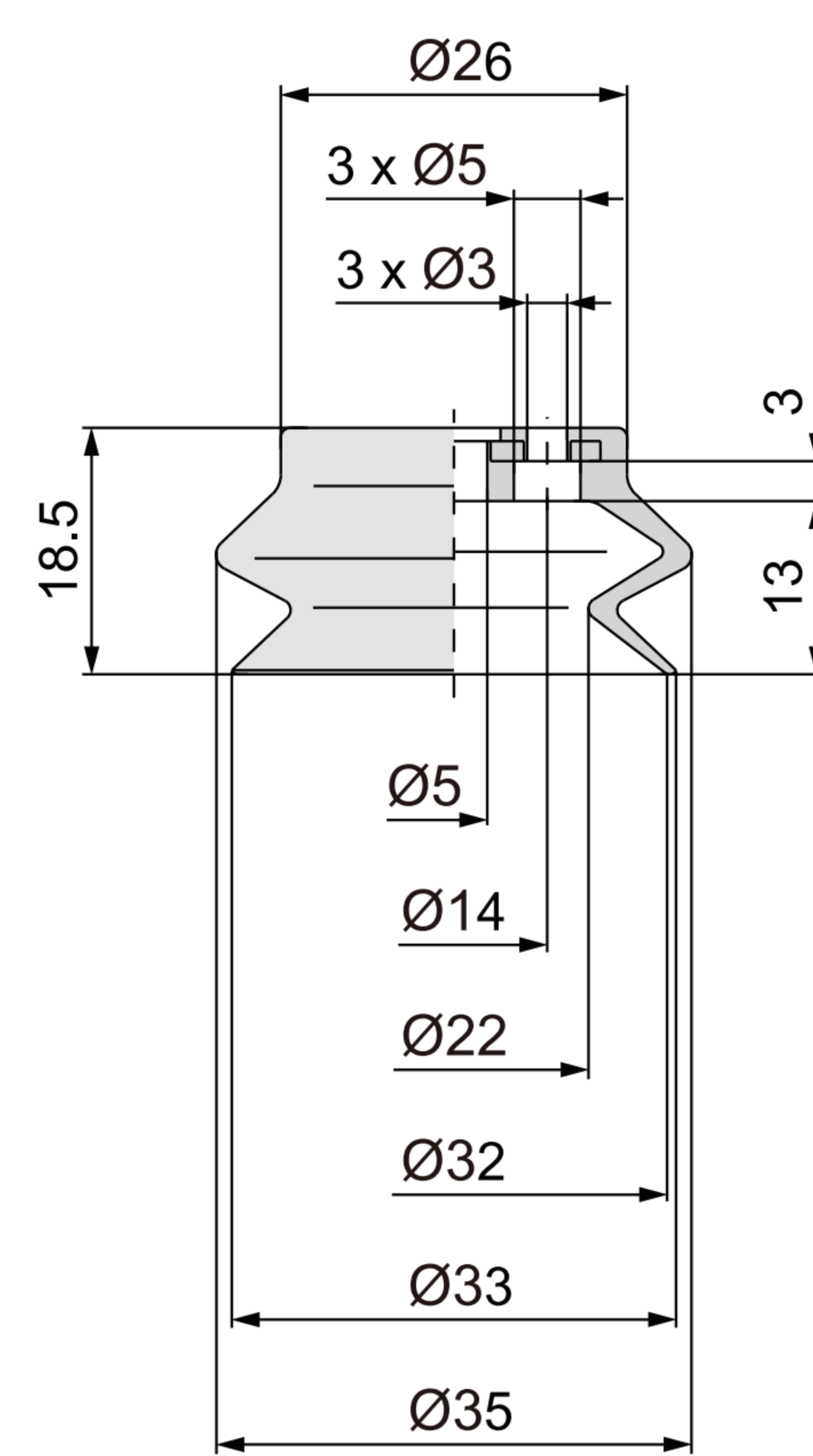

SZP2-32HB□

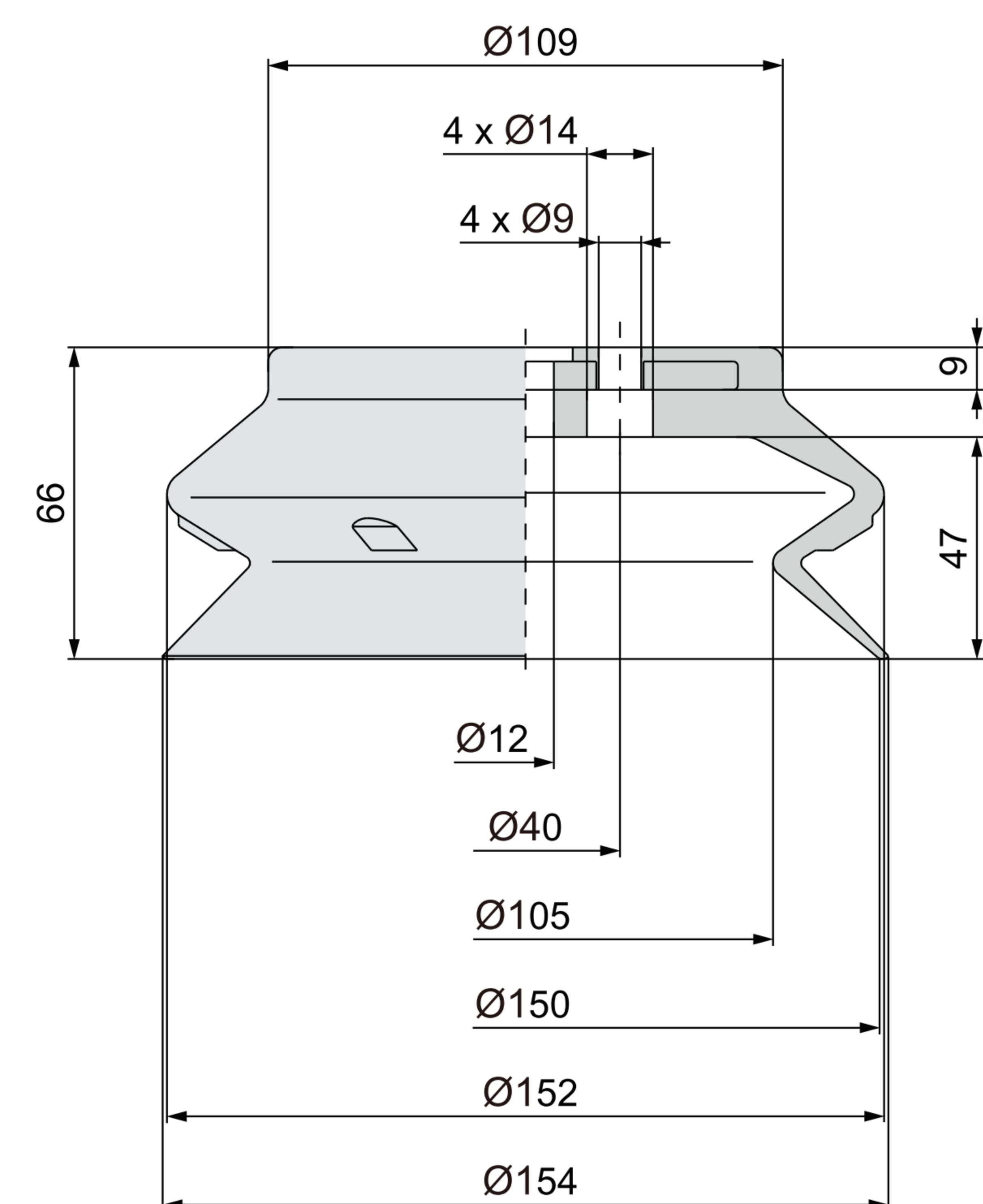

SZP2-150HB□

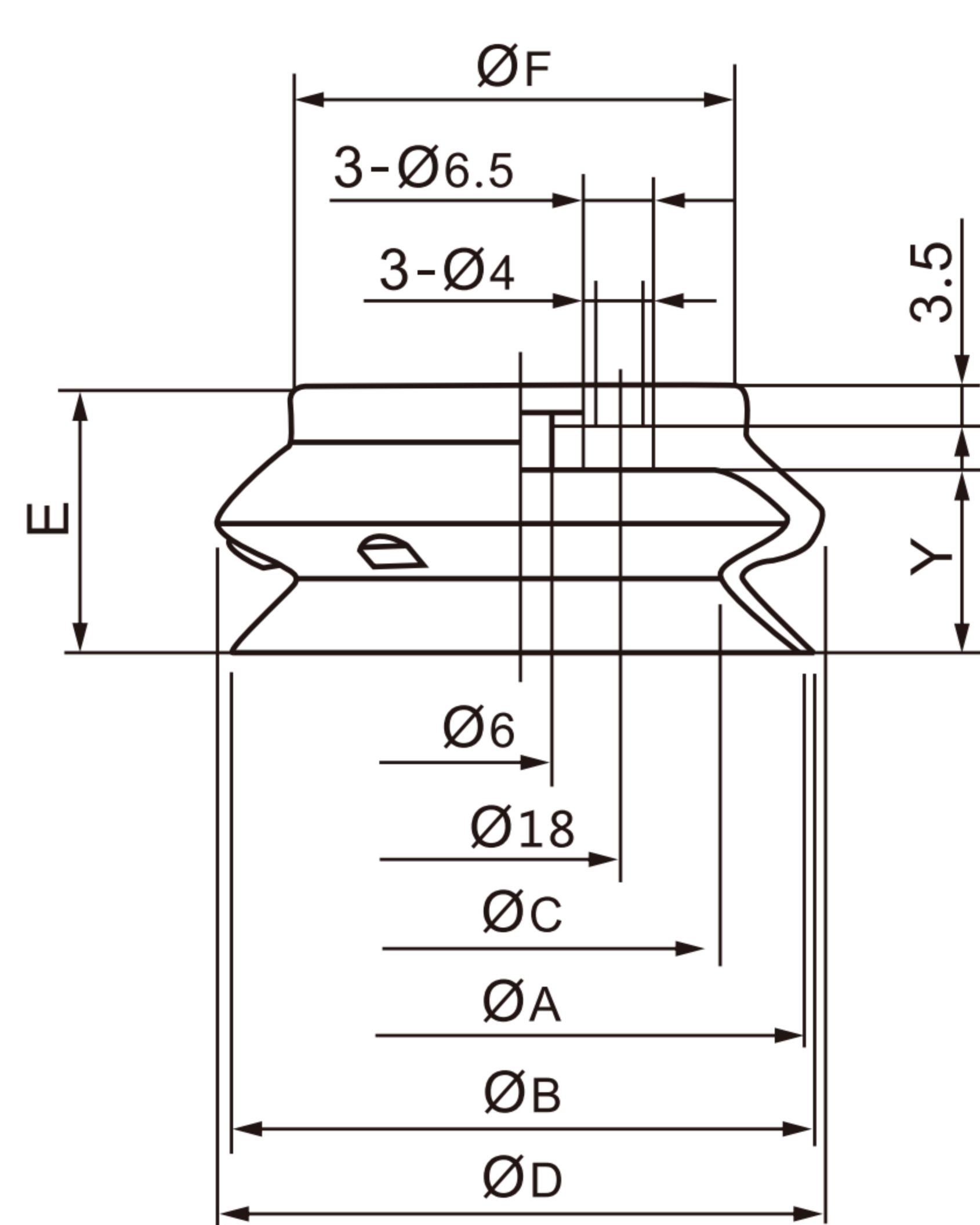

Model	A	B	C	D	E	F	Y
SZP40HB□	40	41.1	28.4	43.2	20.5	30	3.5
SZP40HB□	50	51.9	35.7	54	24	40.5	4.5

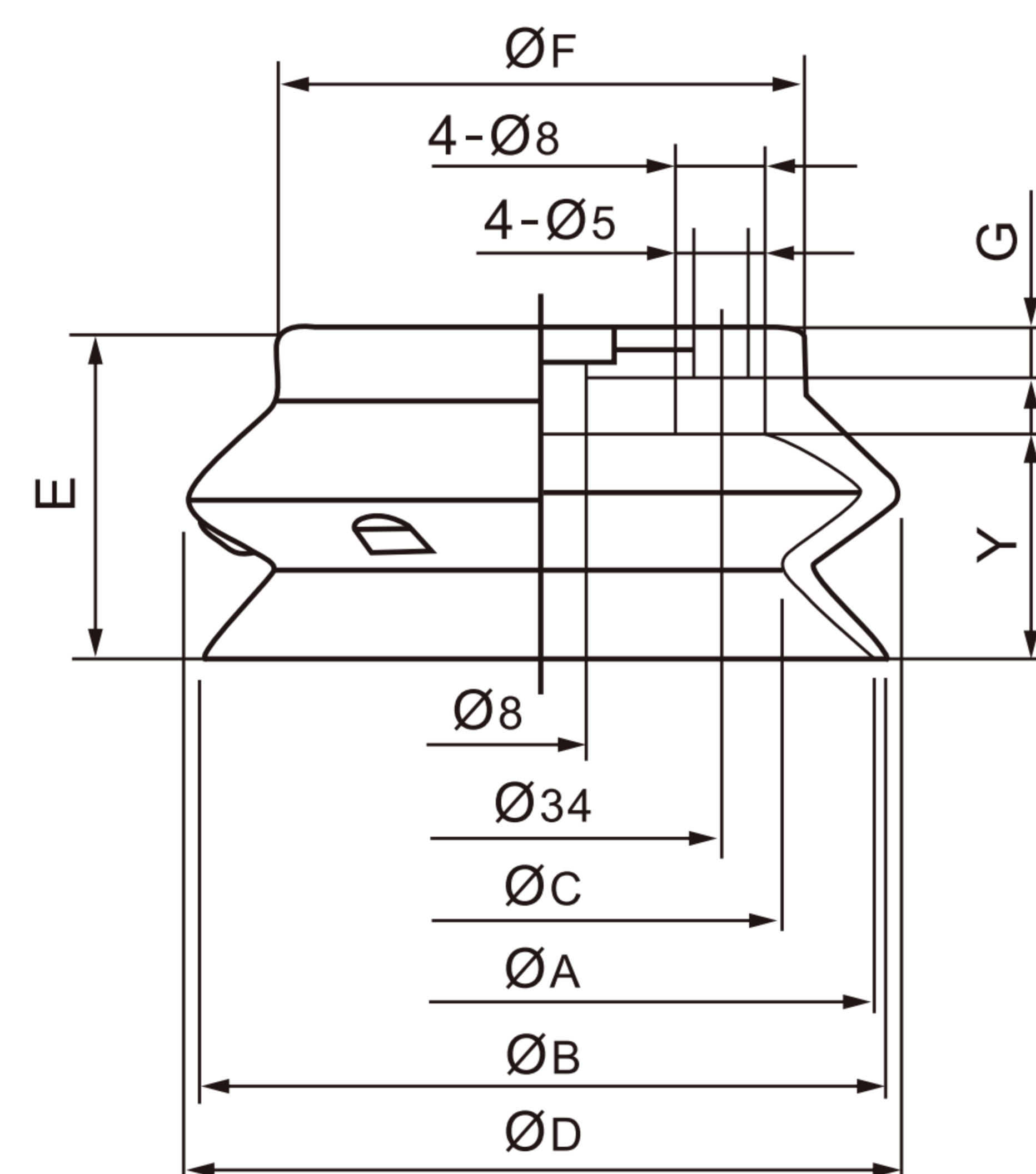

Model	A	B	C	D	E	F	Y
SZP63HB□	63	65.1	45.5	67.6	31.5	50	21.5
SZP80HB□	80	83	58.4	85.1	38	64	27.5

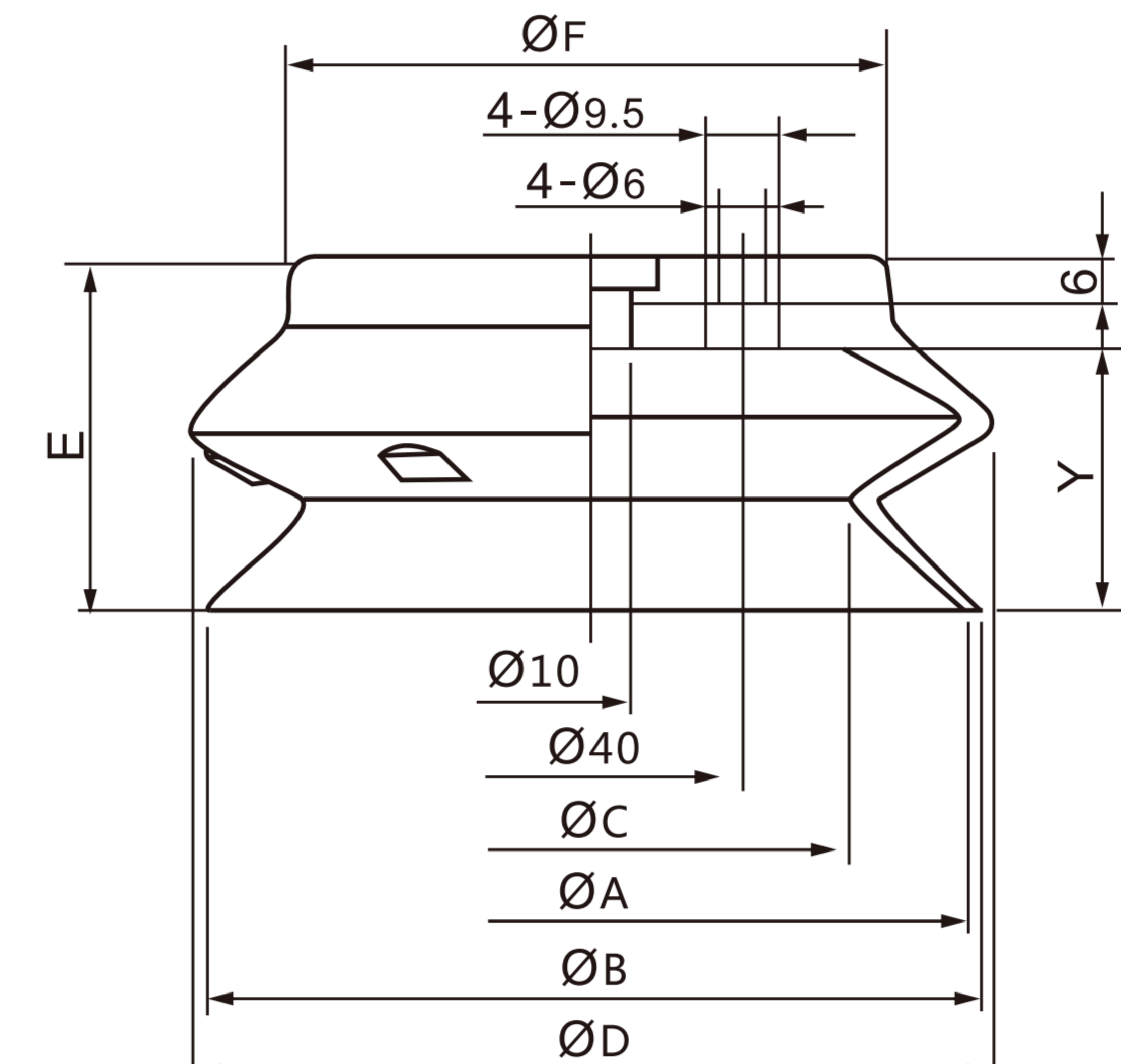

Model	A	B	C	D	E	F	Y
SZP100HB□	100	103	68.6	106.7	47.5	80	35.5
SZP125HB□	125	129	88.6	135	56	105	44