

EAR2000 EAR3000 EAR4000

Regulator

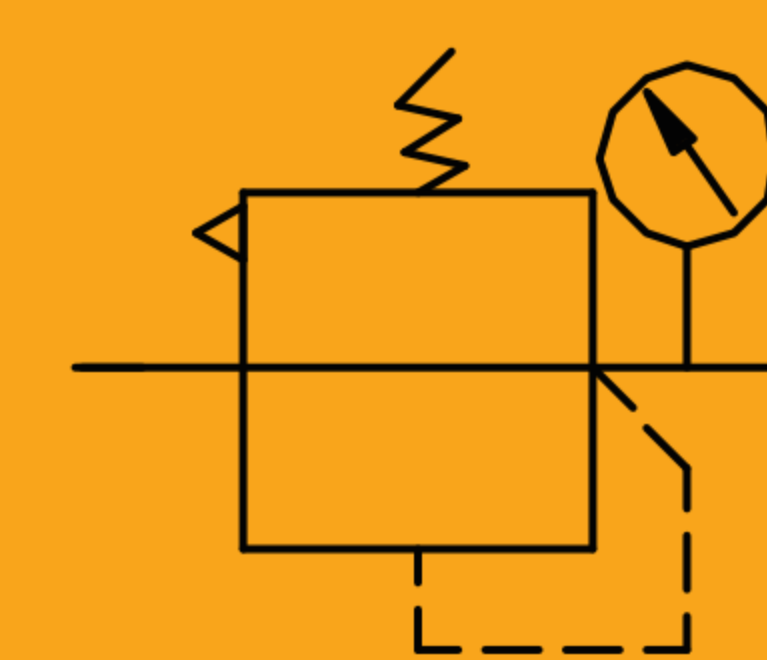

Specifications

Model	EAR2000-01	EAR2000-02	EAR3000-02	EAR3000-03	EAR3000-04	EAR4000-03	EAR4000-04	EAR4000-06
Working Medium	Clean Air(after 40 μ m filtration)							
Proof Pressure(MPa)	1.5							
Max. Working Pressure(MPa)	1.0							
Pressure Adjustment Range(Mpa)	0.05~0.9, Low pressure type 0.05~0.4							
Working Temperature(°C)	-5~60 (No freezing)							
Weight(g)	166		380			684		

How to Order?

Series No.	Port Size	Type No.	Pressure Gauge	Pressure Gauge Type	Bracket Code	Scale Unit	Thread Type
EAR2000:EA2000 series Regulator EAR3000:EA3000 series Regulator EAR4000:EA3000 series Regulator			Blank: With pressure gauge N: No pressure gauge		Blank: With bracket J: No bracket		Blank: G P: PT T: NPT
	2000 01: 1/8" 02: 1/4" ----- 02: 1/4" 3000 03: 3/8" 04: 1/2" ----- 03: 3/8" 4000 04: 1/2" 06: 3/4"	Blank: Standard type	F: Square pressure gauge Y: Round pressure gauge			① Square pressure gauge optional [1: MPa 2: Bar 3: Psi Round pressure gauge optional [4: Mpa/Psi 5: Bar/Psi	

Order Example:

EA series Regulator, port size of 1/2", with square pressure gauge, with bracket, Mpa, G thread, the ERP code is: EAR3000-04F1

Remark: ① Port of round pressure gauge is M6; It is not allowed to distribute pressure gauges to customers.

EAR Series Air Preparation Unit



Internal Structure

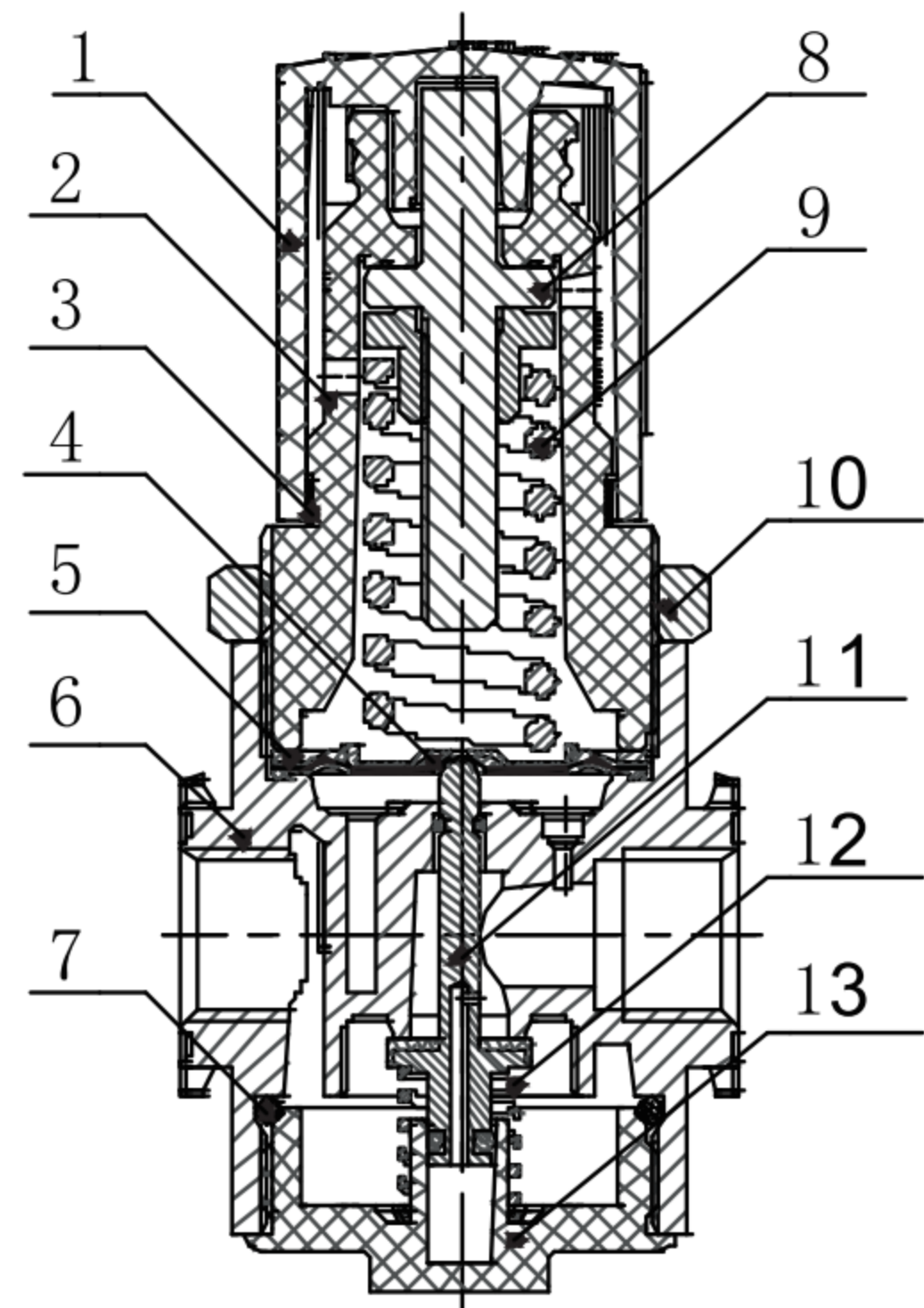

No.	Part Name	Material
1	Pressure regulating handle	Plastics
2	Pressure regulating valve cover	Plastics
3	Marking ring	Plastics
4	Diaphragm	SUS304+NBR
5	Gaskets	6061
6	Valve body	Aluminum alloy
7	Seal	NBR
8	Water bowl	Plastics
9	Pressure regulating screw/ Screw set	Free-cutting steel
10	Spring	SWC
11	Octagonal caps	Aluminum alloy
12	Valve stem	Brass
13	Valve core	SUS304
14	Water separator propeller	Plastics
15	Valve core	Plastics
16	Water baffle	Plastics

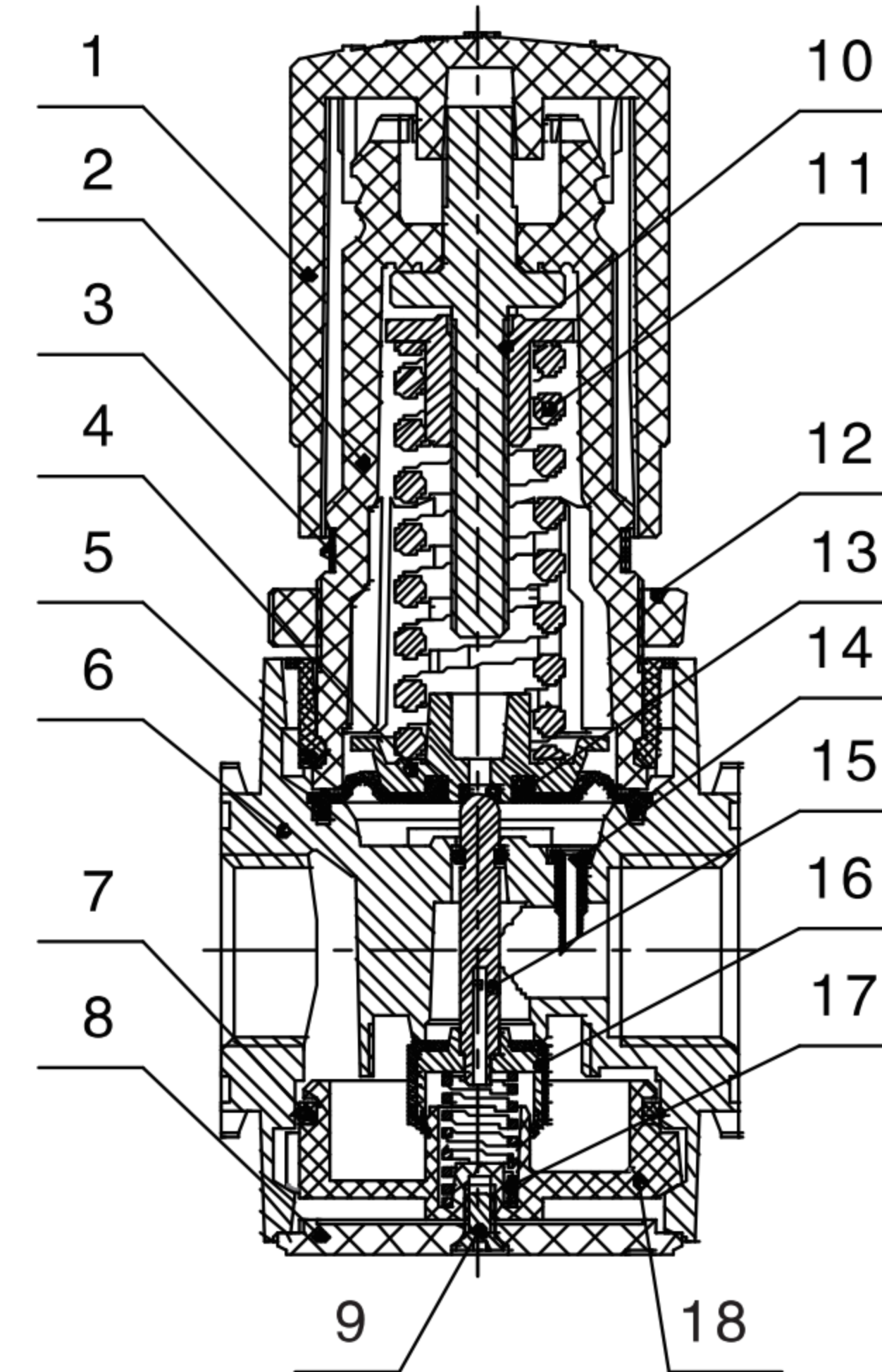

No.	Part Name	Material
1	Pressure regulating handle	Plastics
2	Pressure regulating valve cover	Plastics
3	Marking ring	Plastics
4	Pressure regulating spring seat	Plastics
5	Cover plate	Plastics
6	Valve body	Aluminum alloy
7	Seal	NBR
8	Valve seat cover	Plastics
9	Screw	Mild steel
10	Pressure regulating screw/ Screw set	Free-cutting steel
11	Spring	SWC
12	Octagonal caps	Plastics
13	Diaphragm	NBR
14	Interline	Plastics
15	Valve stem	Brass
16	Valve core	6061+NBR
17	Spring	Plastics
18	Pressure regulating valve seat	Plastics

Pressure Feature

EAR2000

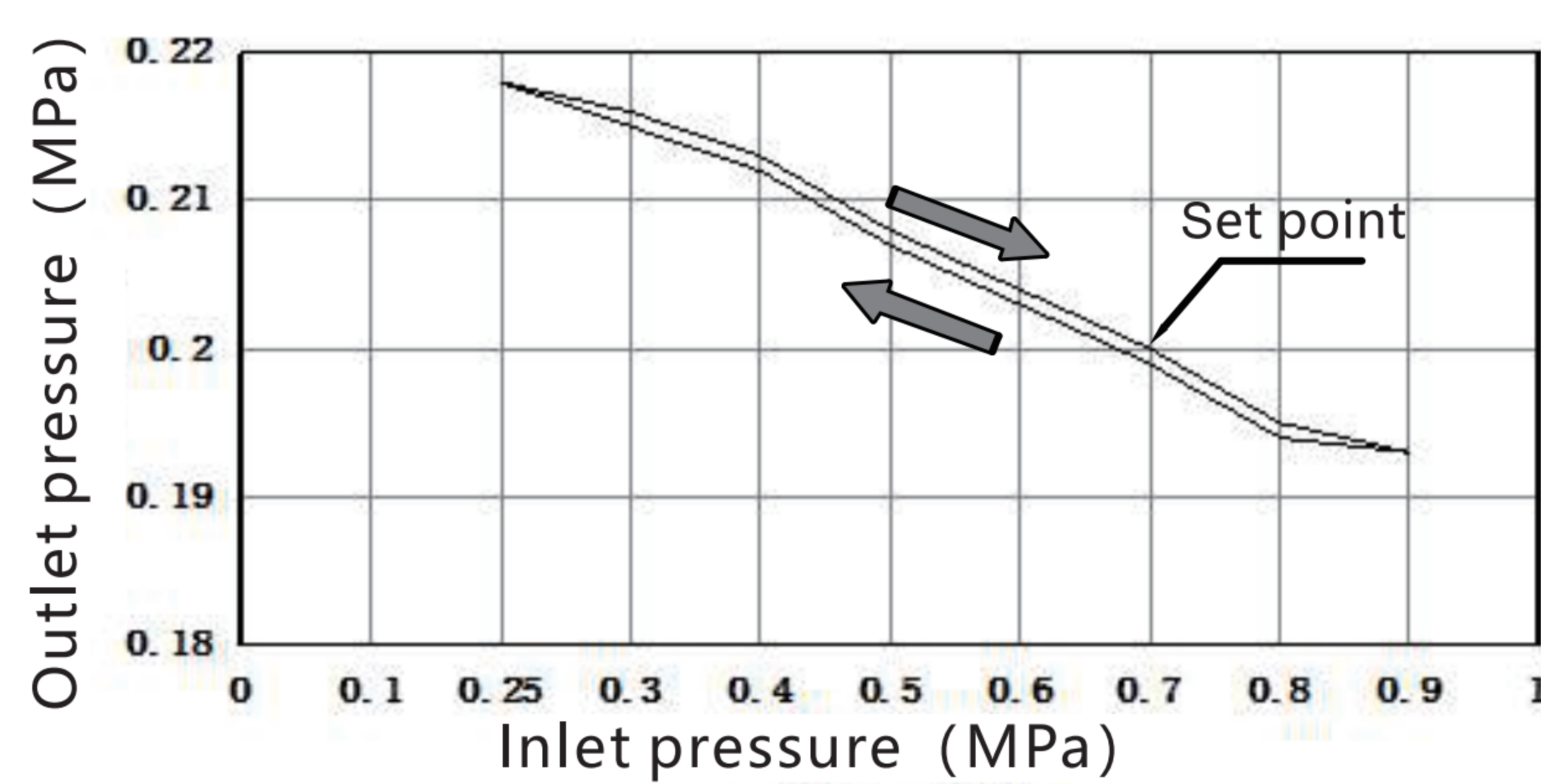

EAR3000

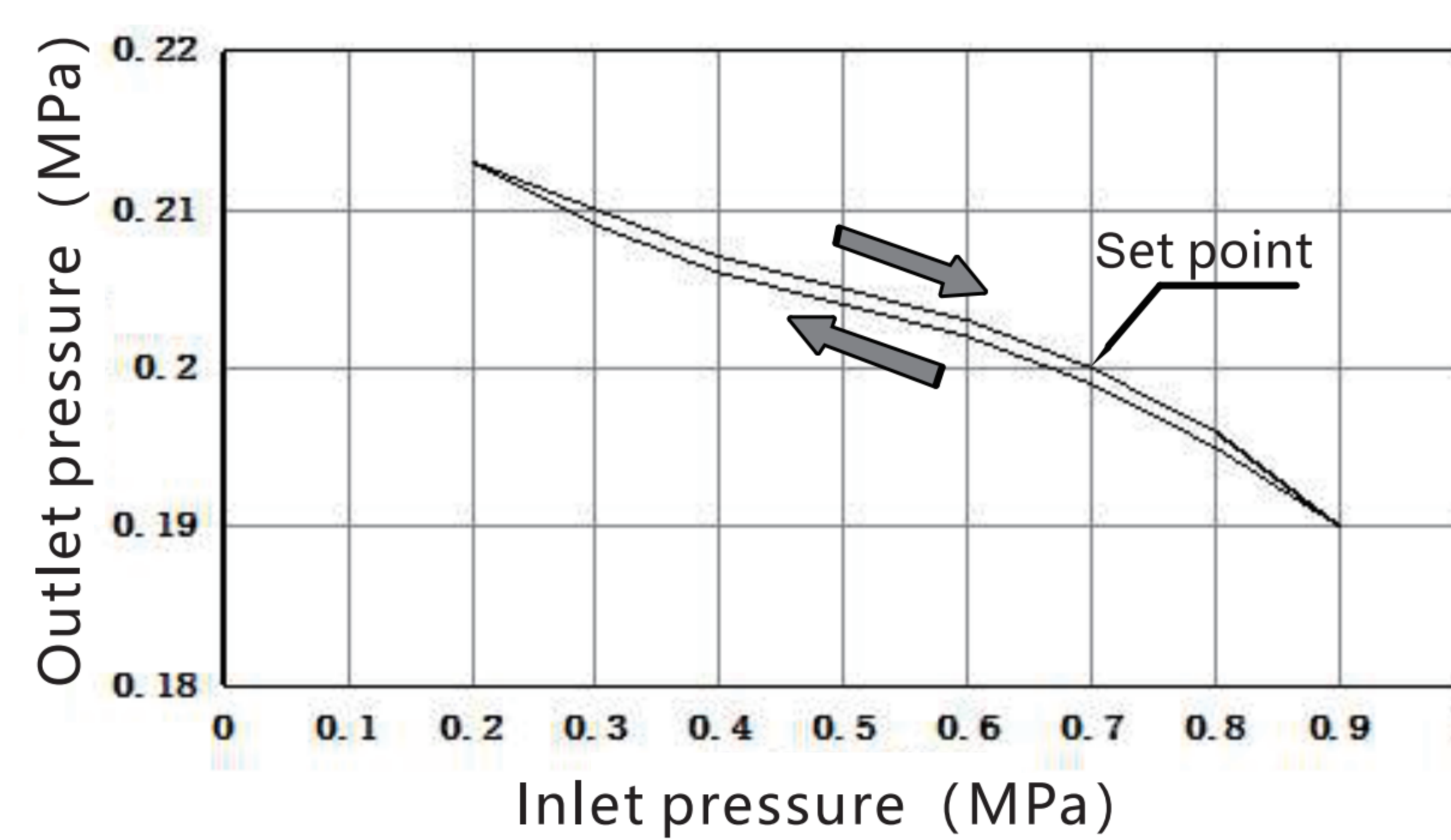

EAR4000

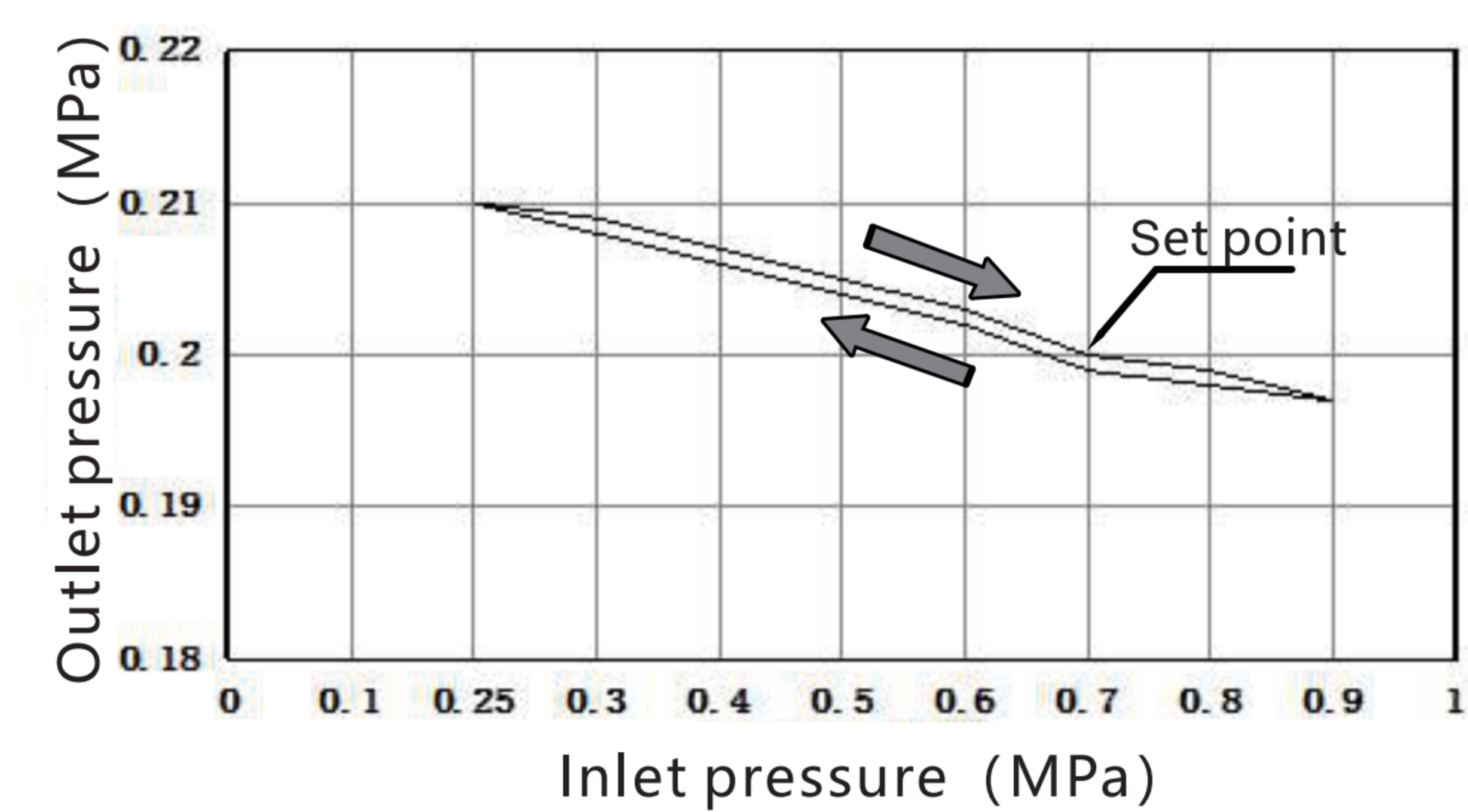

Flow Chart

EAR2000

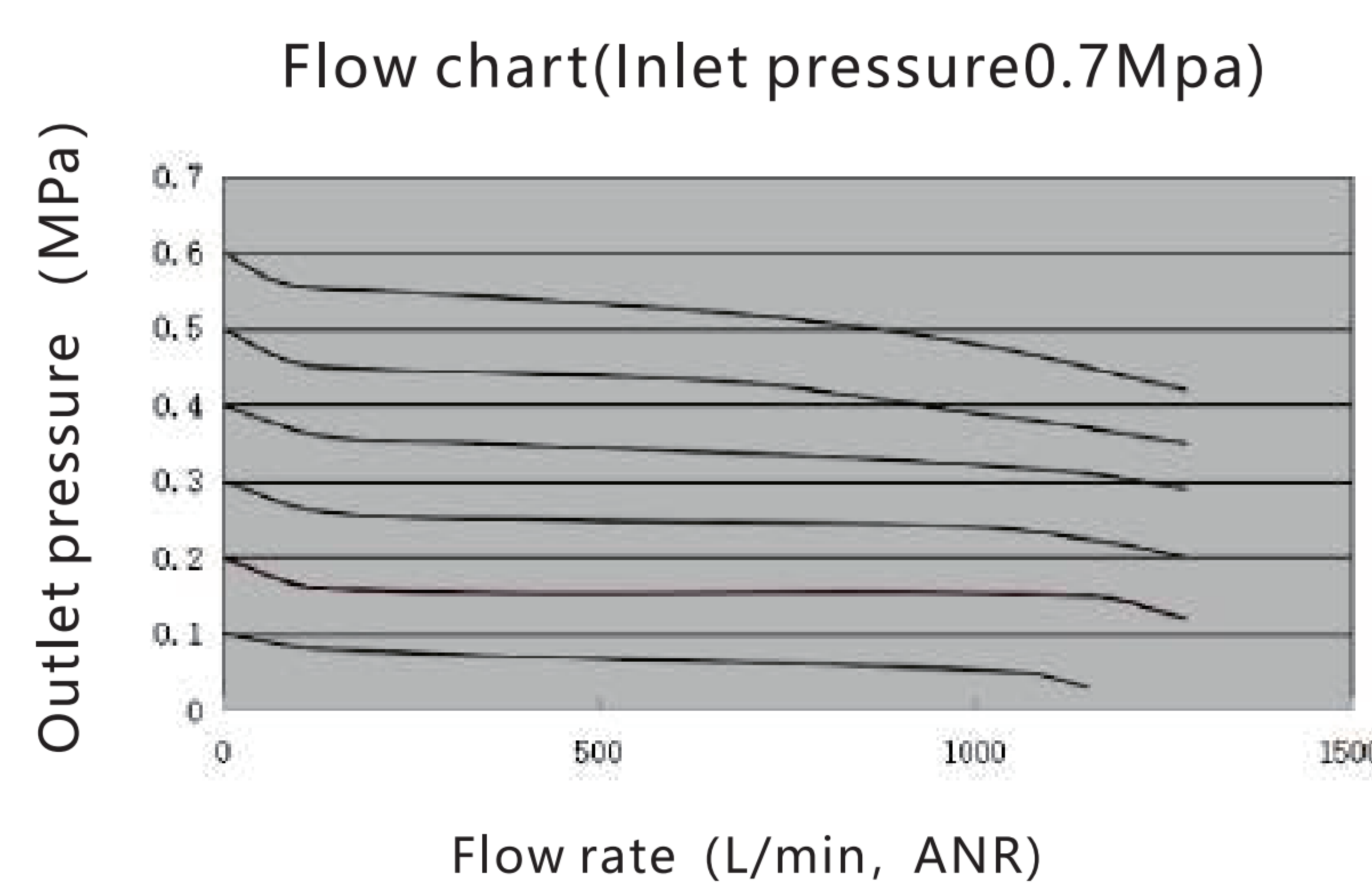

EAR3000

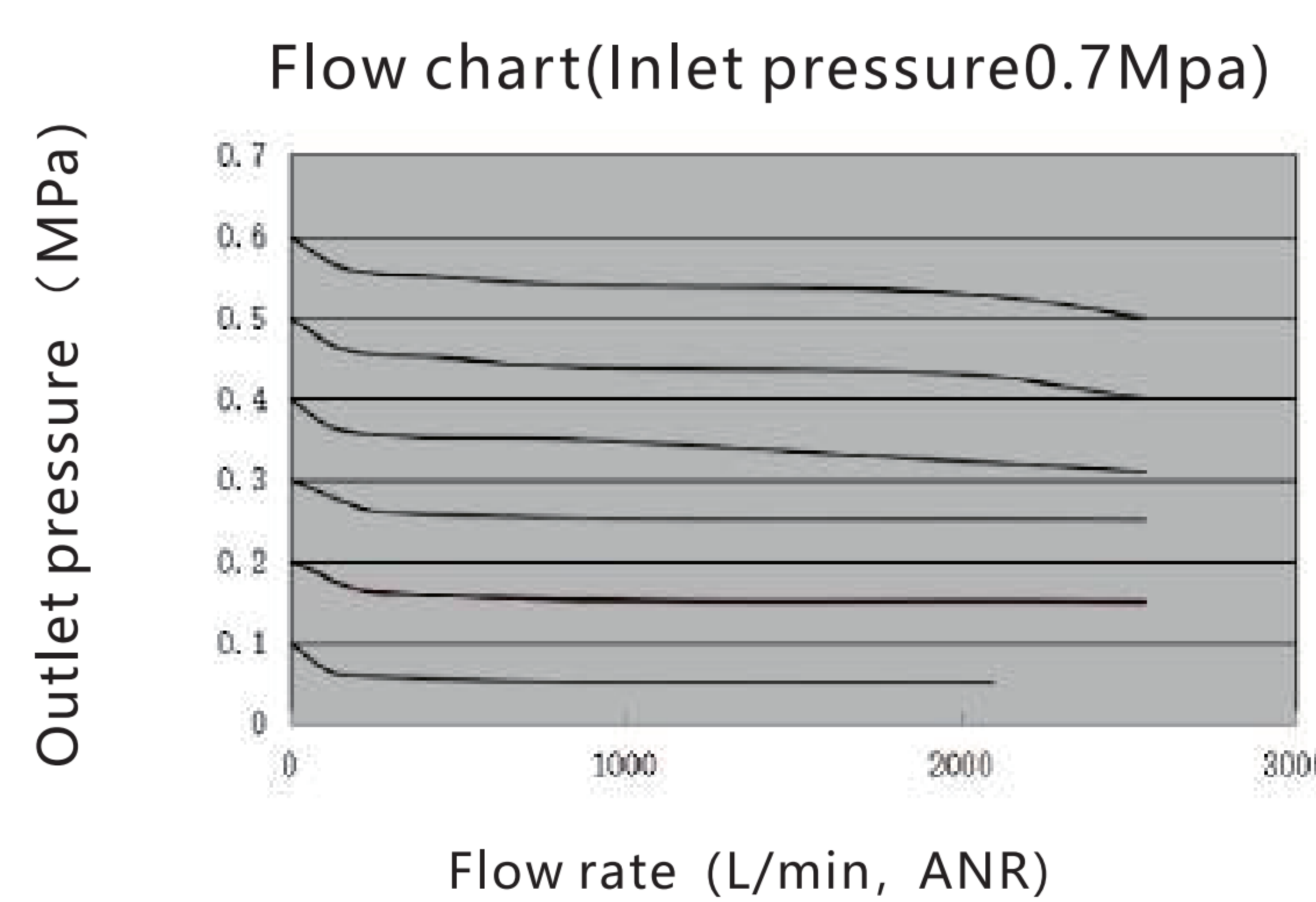

EAR4000

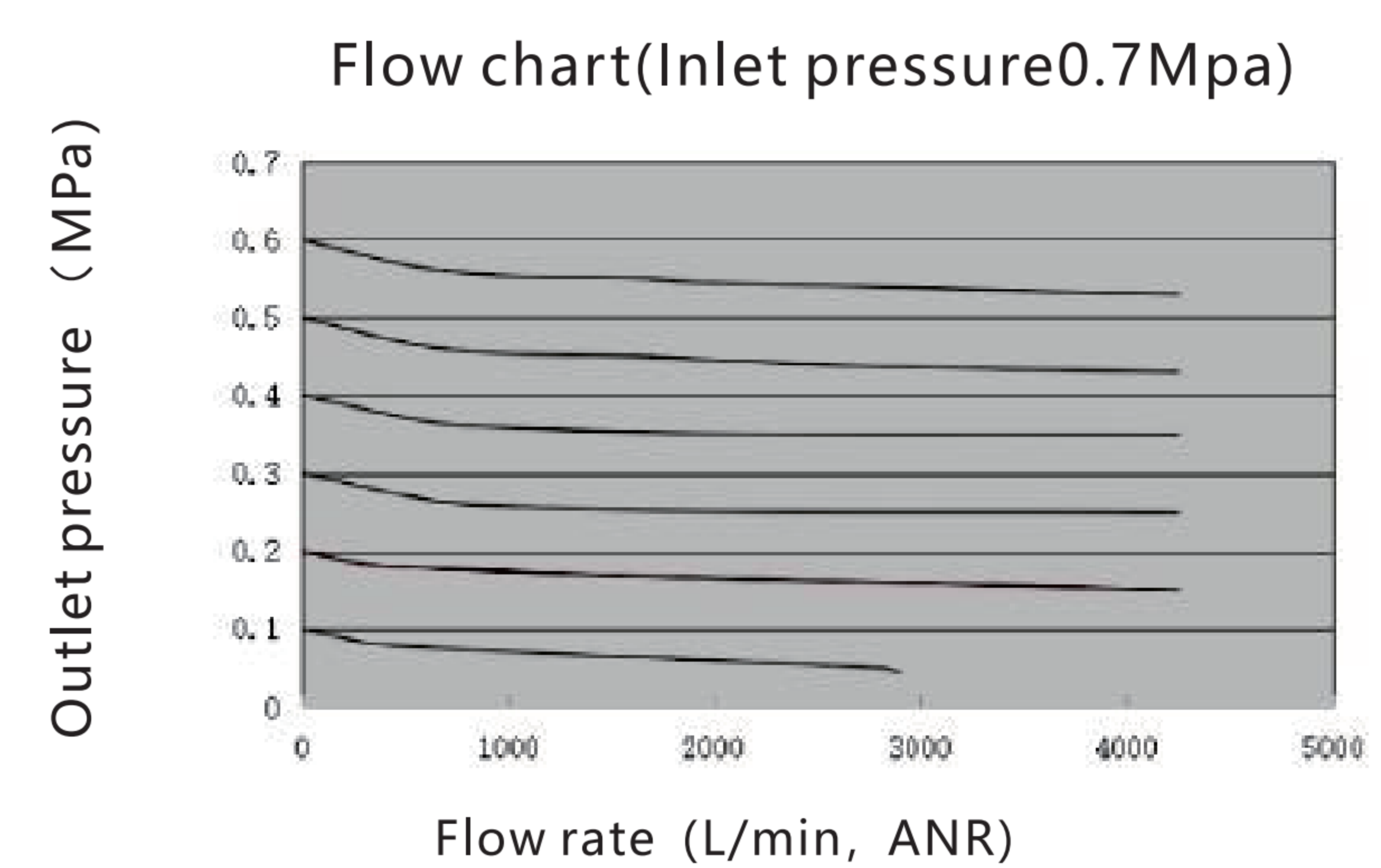

Main Dimensions

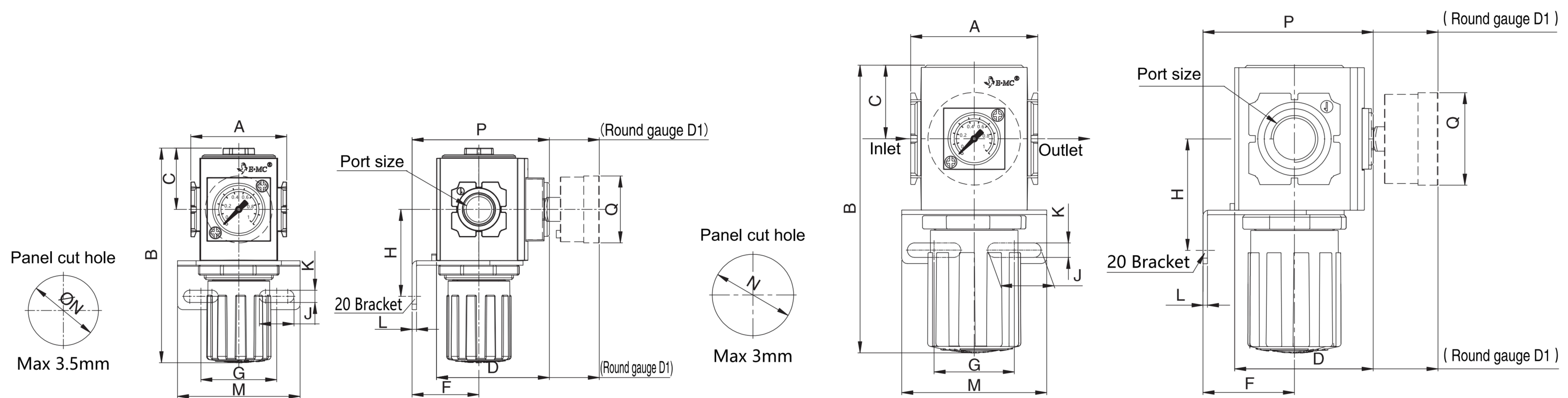

Model	Port Size	A	B	C	D	D1	F	G	H	J	K	L	M	N	P	P1	Q
EAR2000	1/8", 1/4"	43	96.3	27.5	50.6	73	30	34	39	15.5	5.5	2	55	31.5	61.6	84	30
EAR3000	1/4", 3/8", 1/2"	57	129.1	33	62.1	91.2	41	36	50	24	6.5	2	65	36.5	76.3	105.4	41.5
EAR4000	3/8", 1/2", 3/4"	80	141.6	36	82.1	110.7	50	38	53	28	8.5	2.5	72	52.5	95.3	123.9	41.5