

EW

F&R

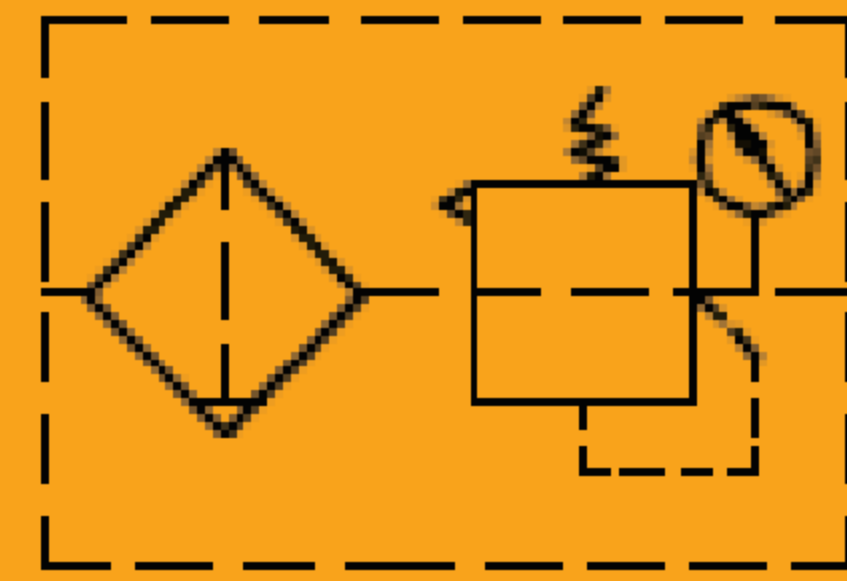

Specifications

Model	EW1000	EW2000	EW3000	EW4000	EW5000
Proof pressure(MPa)	1.5				
Max. working pressure (MPa)	1.0				
Working temperature(°C)	-5~60 (No freezing)				
Filter precision	25 μm (5 μm is optional)				
Bowl material	Polycarbonate				
Bowl guard	None		Available		
Pressure adjusting range (MPa)	0.15~0.85				
Valve type	With overflow				

Model	Specifications				Accessories		Drain function	Auto drain model
	*Rated flow(L/min)	** Port size (G)	Pressure gauge thread size	Weight (kg)	Bracket			
EW1000-M5	100	M5	1/16	0.09	B120			
EW2000-01	1078	1/8	1/8	0.36	B220		EW2000-01D	
EW2000-02	1165	1/4					EW2000-02D	
EW3000-02	1998	1/4	1/8	0.56	B320		EW3000-02D	
EW3000-03	2177	3/8					EW3000-03D	
EW4000-03	5108	3/8	1/4	1.15	B420		EW4000-03D	
EW4000-04	5211	1/2					EW4000-04D	
EW4000-06	5750	3/4	1/4	1.21			EW4000-06D	
EW5000-06	6200	3/4					EW5000-06D	
EW5000-10	6400	1	1/4	1.70			EW5000-10D	

Main Dimension

EW1000-EW2000

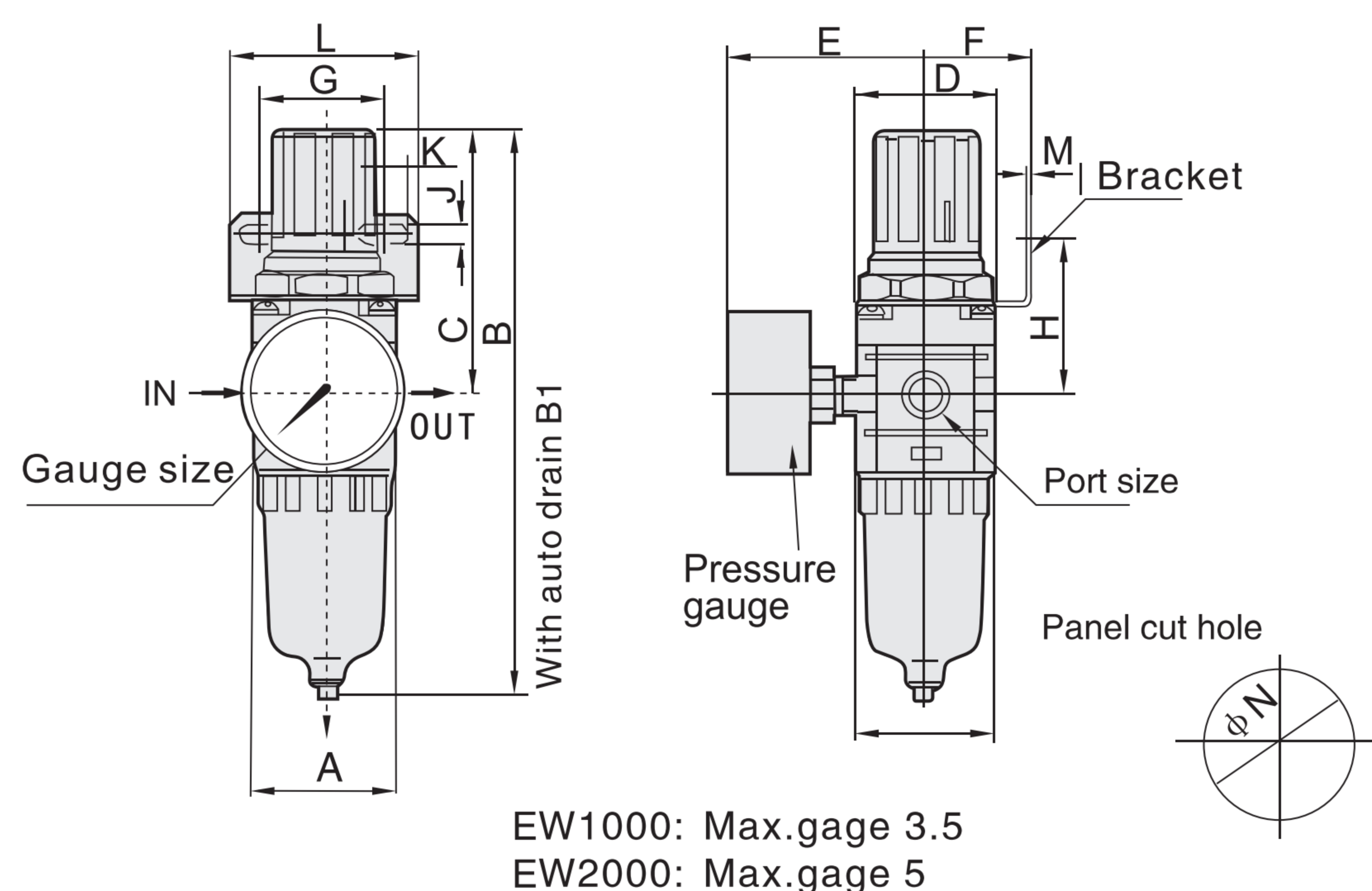

EW3000-EW5000

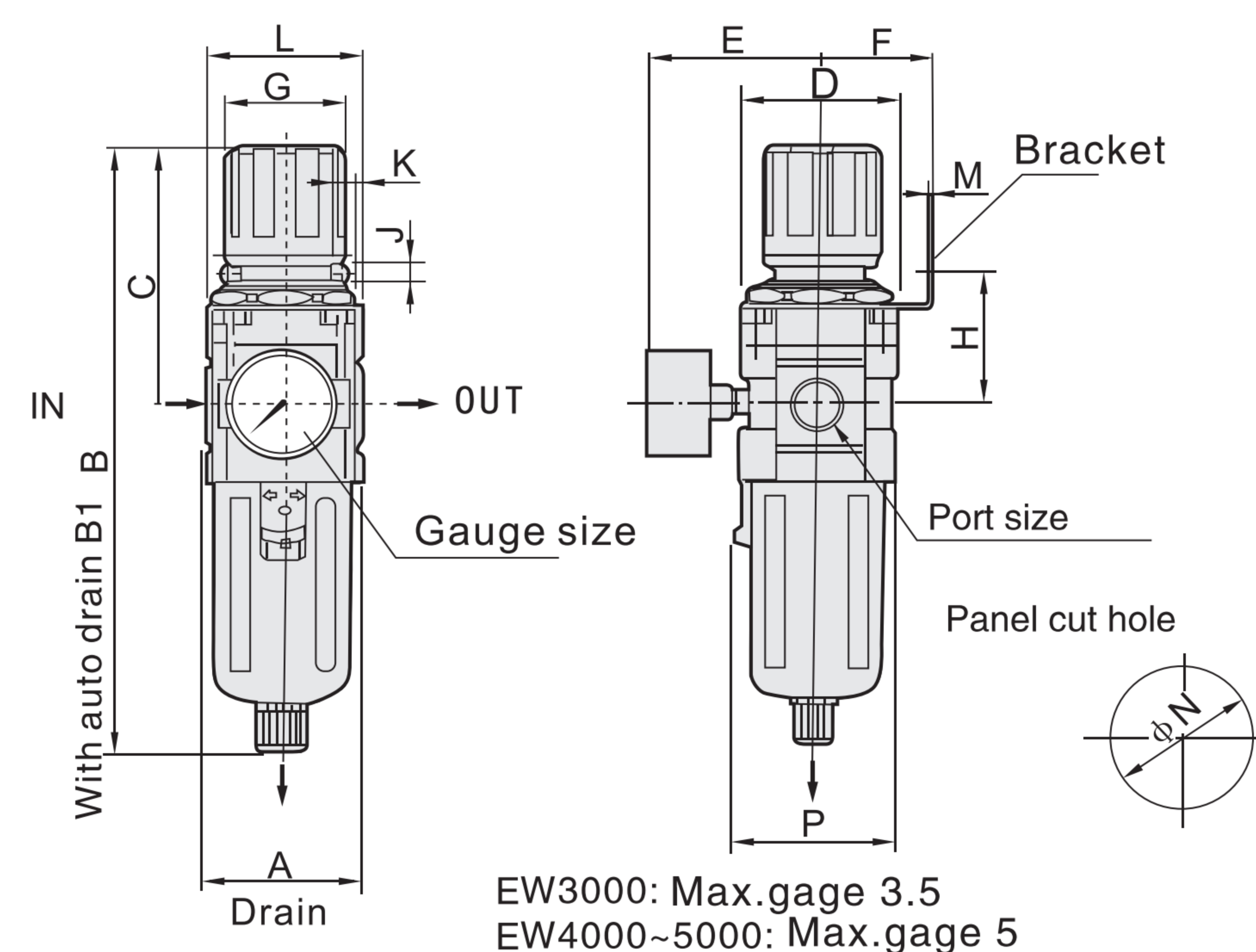

Model	Port Size (G)	A	B	B1	C	D	E	F	G	H	J	K	L	M	N	P
EW1000	M5	25	109.5	-	50.5	25	26	25	28	30	4.5	6.5	40	2	20.5	28
EW2000	1/8"-1/4"	40	162	200	76	40	53	30.5	33.5	43	5.4	15	55	2	33	40
EW3000	1/4"-3/8"	53	210.5	224.5	92	53	57	39	40	45	6.5	8	53	2	42	56
EW4000	3/8"-1/2"	70	264	267	113.5	70	67	48	53.5	53.5	8.5	10.5	70	2	52	73
EW4000-06	3/4"	75	268	271	115	70	67	48	53.5	53.5	8.5	10.5	70	2	52	73
EW5000	3/4"-1"	90	343	348	116.5	90	72	48	53.5	62	8.5	10.5	70	2	52	90