

EUM Series Mini Type Free Mount Cylinder

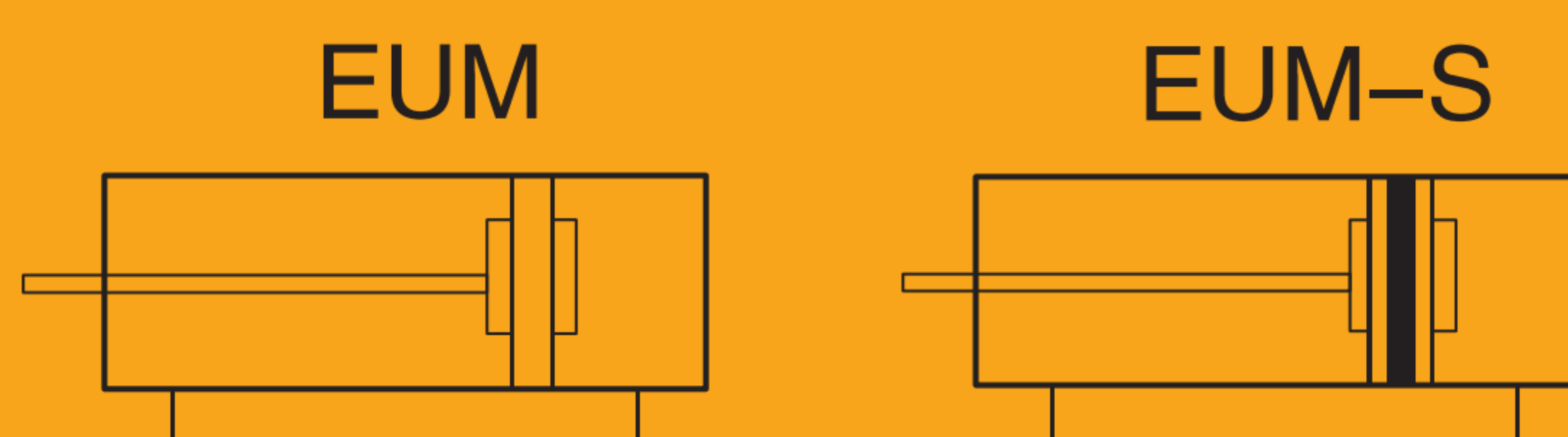

EUM

Minitype Free Mount Cylinder



Specifications

Bore(mm)	6	8	10	12	16	20
Acting Type	Double Acting					
Working Medium	Clean Air(after 40 μ m filtration)					
Working Pressure(MPa)	0.15~0.7					
Guaranteed Pressure(MPa)	1.05					
Working Temperature(°C)	-20~70(No freezing)					
Piston Speed(mm/s)	30~500					
Cushion	None			Rubber cushion		
Stroke tolerance	+1.0 0					
Port Size	M3 × 0.5				M5 × 0.8	

How to order?

Series No.	Type No.	Bore	X Stroke	Magnet No.	Piston Rod Thread Type	Mounting Type
EUM	Blank: Basic type	6 8 10 12 16 20	4 6 8	Blank: No magnet S: With magnet	Blank: Female thread M: Male thread	Blank: Lateral mounting R: Axial mounting (Note:ø6,ø8,ø10 is not available)

Order Example:

EUM series basic type cylinder, bore 10, stroke 20, with magnet, male thread
The ERP code is: EUM10X20-S-M

Optional Accessories

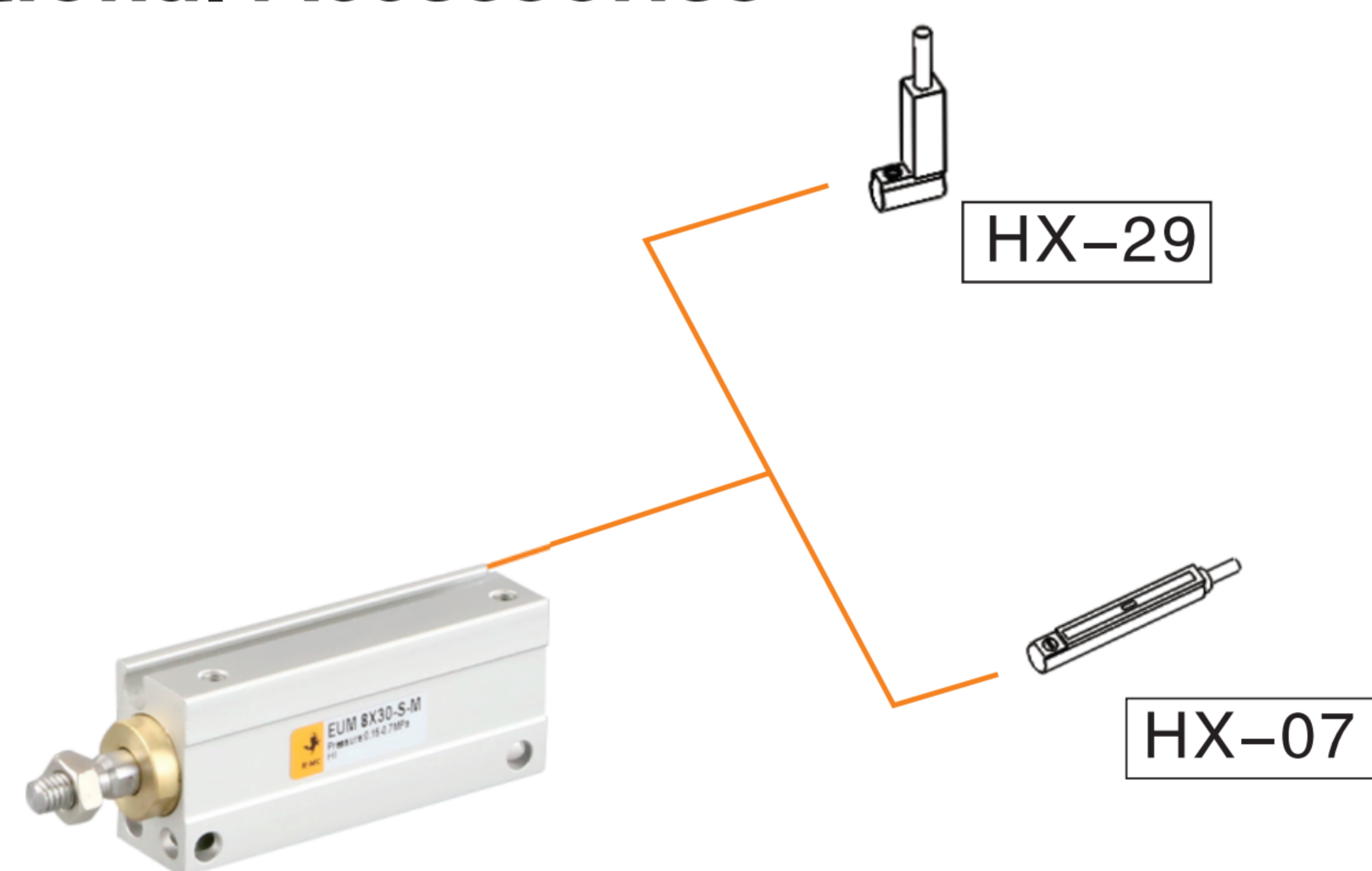

Note: Short stroke please use HX-29 series due to limited space.

Stroke

Bore(mm)	Standard Stroke(mm)	Max.Stroke(mm)
6	4 6 8 10 15 20 25 30	30
8	4 6 8 10 15 20 25 30	30
10	4 6 8 10 15 20 25 30	30
12	5 10 15 20 25 30 35 40 45 50	50
16	5 10 15 20 25 30 35 40 45 50	50
20	5 10 15 20 25 30 35 40 45 50	50

Note: The dimensions of non-std stroke cylinder has the same dimensions as the next longer stroke std. stroke cylinder.
e.g. 27mm stroke cylinder has the same dimensions of 30 std. stroke cylinder.
When ordering stroke is larger than the maximum stroke, please contact us.

Internal Structure

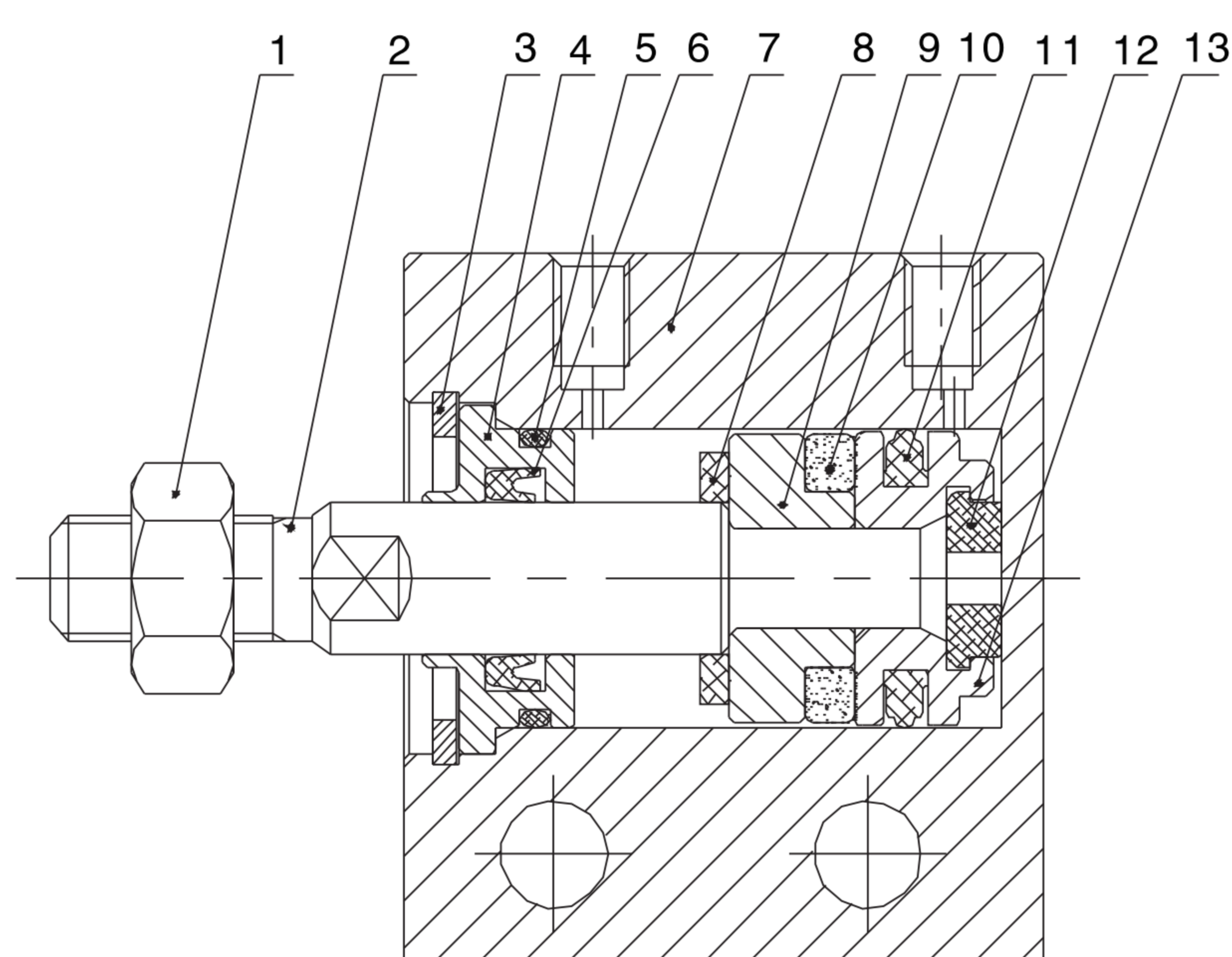

No.	Part Name	Material
1	Nut	Carbon steel
2	Piston Rod	SUS 304 hard chrome carbon steel
3	Snap ring	Spring steels
4	Head cover	Cu/Aluminum alloy
5	O-ring	NBR
6	Head cover o-ring	NBR
7	Barrel	Aluminum Alloy
8	Anti-bump cushion	NBR
9	Magnet Seat	SUS304/Aluminum alloy
10	Magnet	NdFeB
11	Piston seal	NBR
12	Anti-bump cushion	TPU
13	Piston	SUS304/Cu/Aluminum alloy

◎ Main Dimensions

Ø6-Ø10

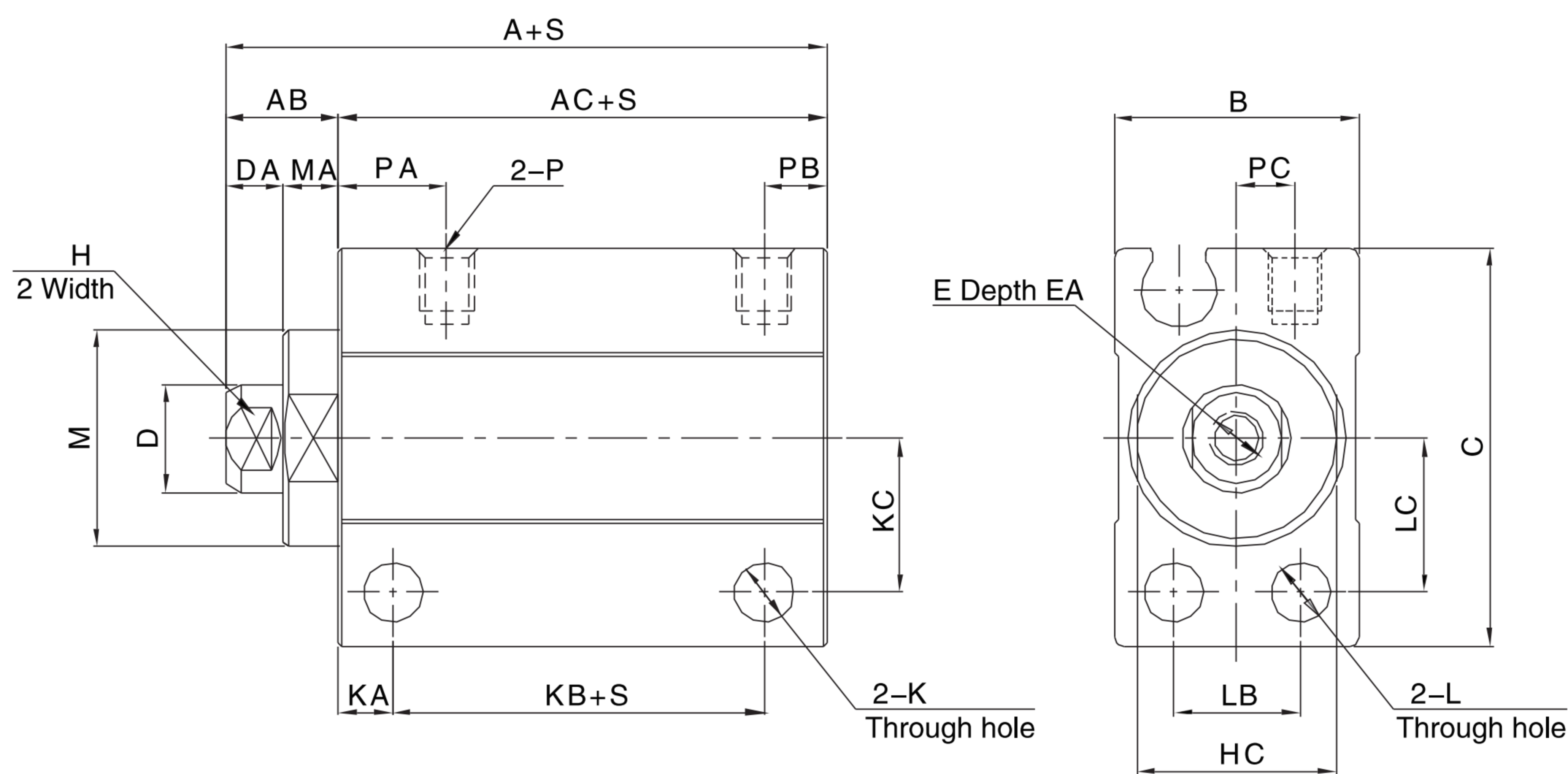

	A		AB	AC		B	C	D	DA	E	EA	H	HC
	No magnet	With magnet		No magnet	With magnet								
6	19	24	6	13	18	13	19	4	3	M2.5X0.45	5	3.5	8
8	19	24	6	13	18	13	21	5	3	M3X0.5	6	4.5	10
10	19	24	6	13	18	13.5	22	6	3	M3X0.5	6	5	11

Bore/Sign	K	KA	KB		KC	L	LB	LC	M	MA	P	PA	PB	PC
			No magnet	With magnet										
6	3.3	3	6.5	11.5	7	3.3	7	7	9	3	M3X0.5	6	3.5	3
8	3.3	3	6.5	11.5	8	3.3	7	8	11	3	M3X0.5	6	3.5	3
10	3.3	3	6.5	11.5	8.5	3.3	7	8.5	12	3	M3X0.5	6	3.5	3.2

Ø6-Ø10 (Male Dimensions)

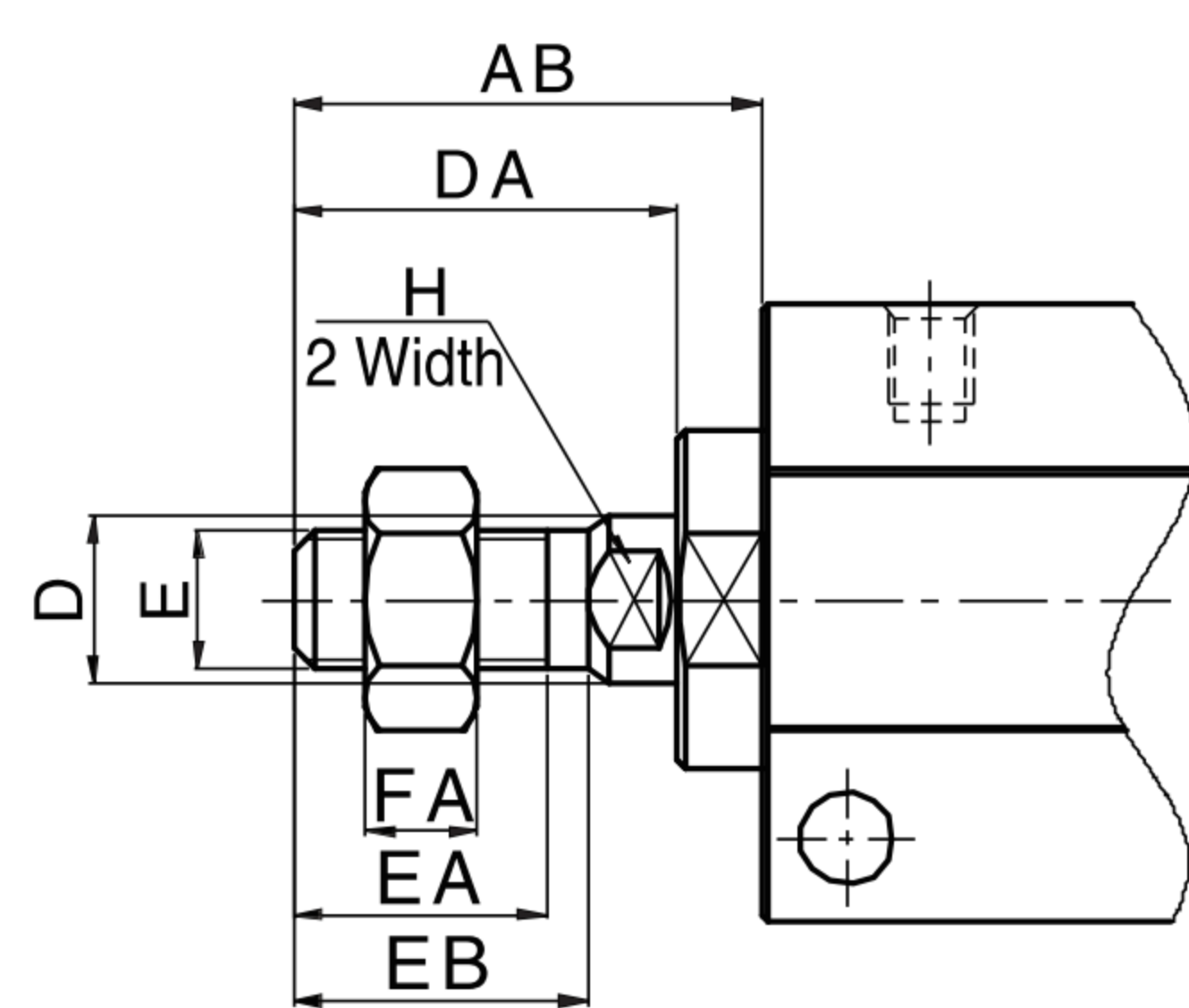

Bore/Sign	AB	D	DA	E	EA	EB	FA	H
6	12.5	4	9.5	M3X0.5	5.5	6.5	2.5	3.5
8	14.5	5	11.5	M4X0.7	7	8.5	3	4.5
10	16.5	6	13.5	M5X0.8	9	10.5	4	5

Note: Not marked dimensions are same sizes as the female type.

Ø12-Ø20 (Lateral Type)

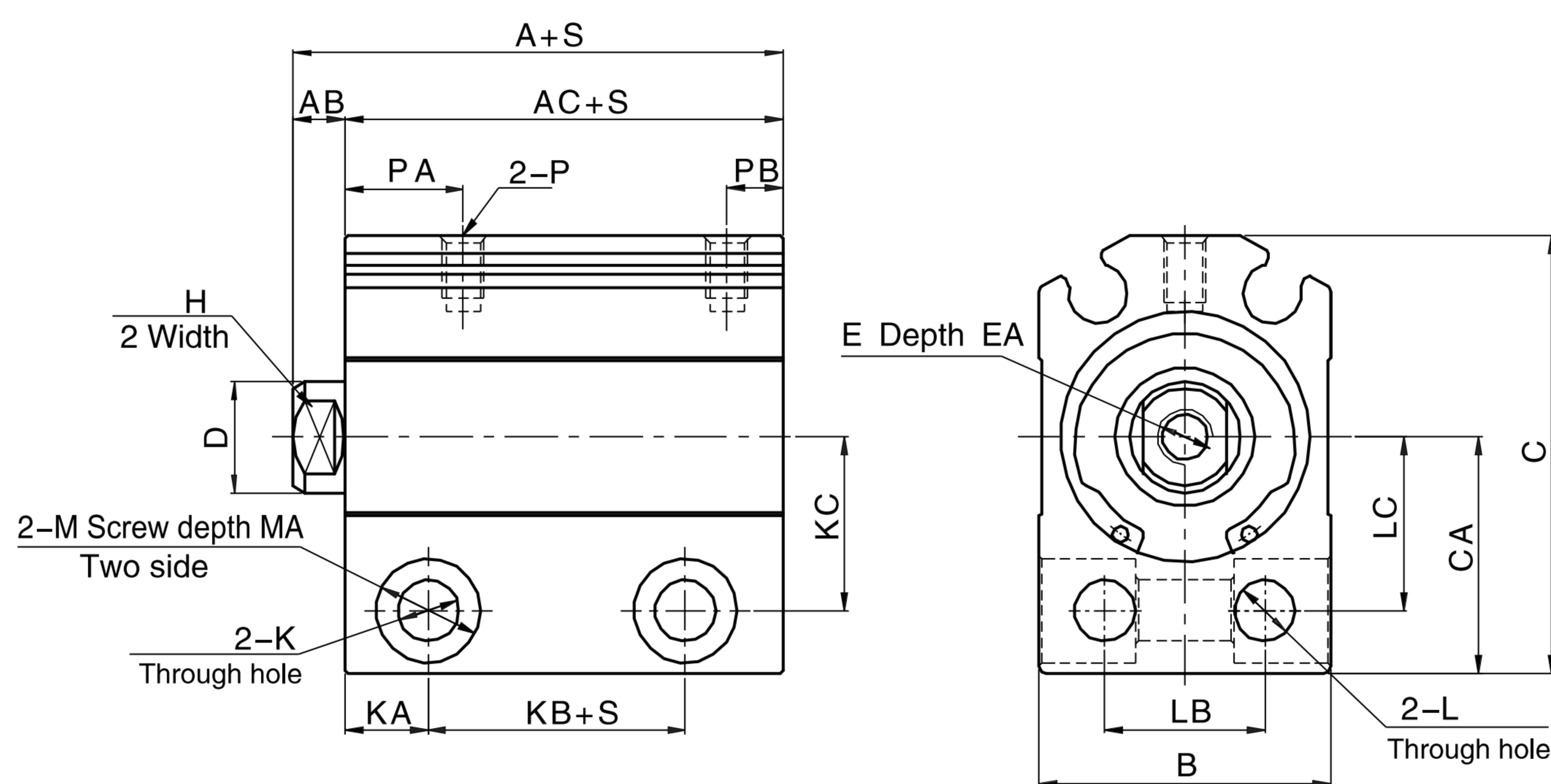

Bore/Sign	A		AB	AC		B	C	CA	D	E	EA	H	K	KA
	No magnet	With magnet		No magnet	With magnet									
12	19	24	3.5	15.5	20.5	17	28.5	15.5	6	M3X0.5	6	5	4.4	6
16	20	25	3.5	16.5	21.5	21	31.5	17	8	M4X0.7	8	6	4.4	6
20	24	29	4.5	19.5	24.5	25	38.5	21	10	M5X0.8	7	8	5.5	7

Bore/Sign	KB		KC	L	LB	LC	M	MA	P	PA	PB
	No magnet	With magnet									
12	3.5	8.5	11	4.4	8	11	7.5	7	M5X0.8	7.5	4
16	4	9	12.5	4.4	11.5	12.5	7.5	7	M5X0.8	8.5	4
20	5.5	10.5	15.5	5.5	13.5	15.5	9.5	9	M5X0.8	8.5	5.5

Ø12-Ø20 (Axial Type)

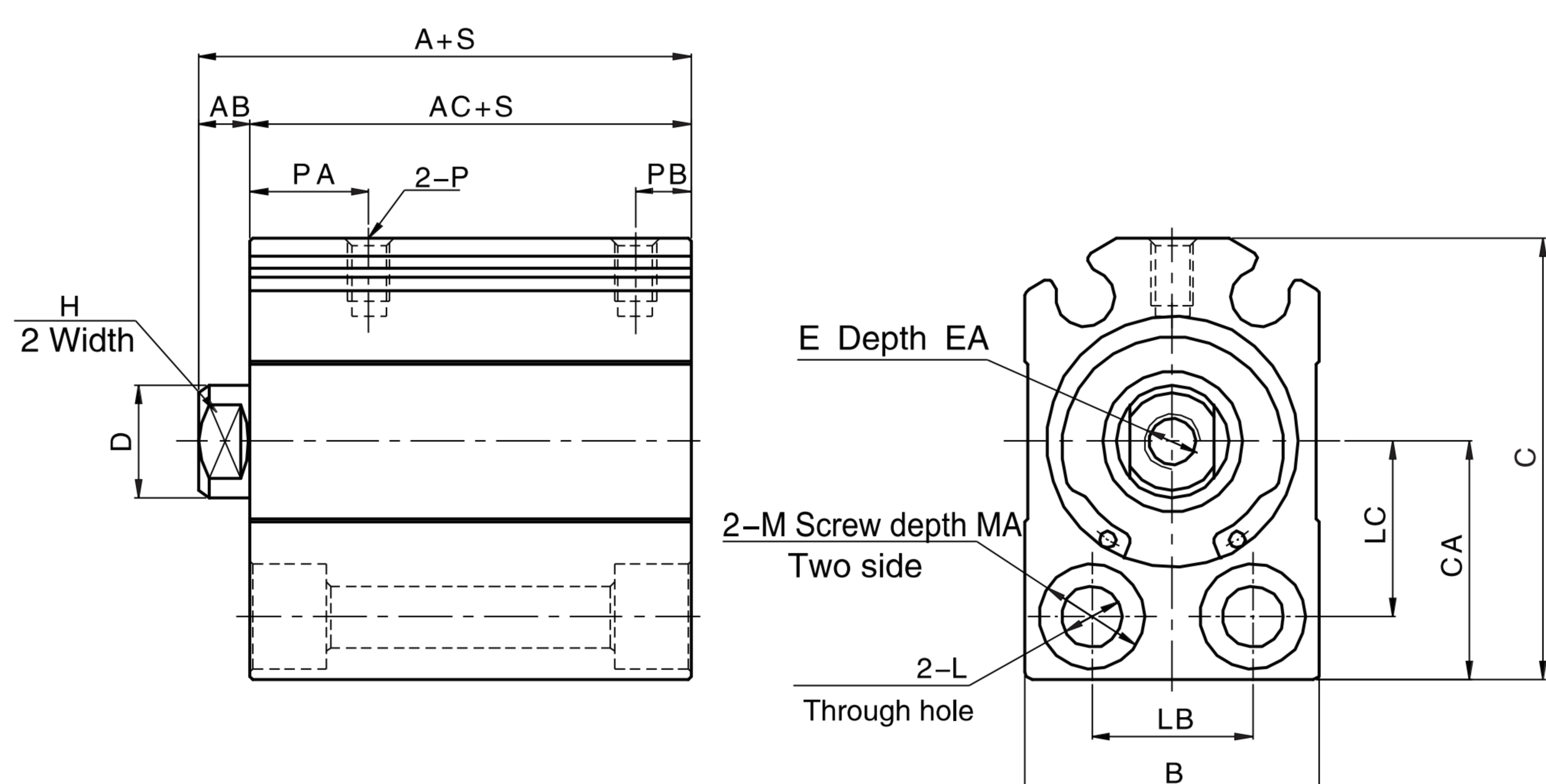

Bore/Sign	A		AB	AC		B	C	CA	D	E	EA	H
	No magnet	With magnet		No magnet	With magnet							
12	19	24	3.5	15.5	20.5	17	28.5	15.5	6	M3X0.5	6	5
16	20	25	3.5	16.5	21.5	21	31.5	17	8	M4X0.7	8	6
20	24	29	4.5	19.5	24.5	25	38.5	21	10	M5X0.8	7	8

Bore/Sign	LB	LC	M	MA	P	PA	PB
12	8	11	7.5	5.5	M3X0.5	7.5	4
16	11.5	12.5	7.5	5.5	M3X0.5	8.5	4
20	13.5	15.5	9.5	6.5	M5X0.8	8.5	5.5

Ø12-Ø20 (Male Dimensions)

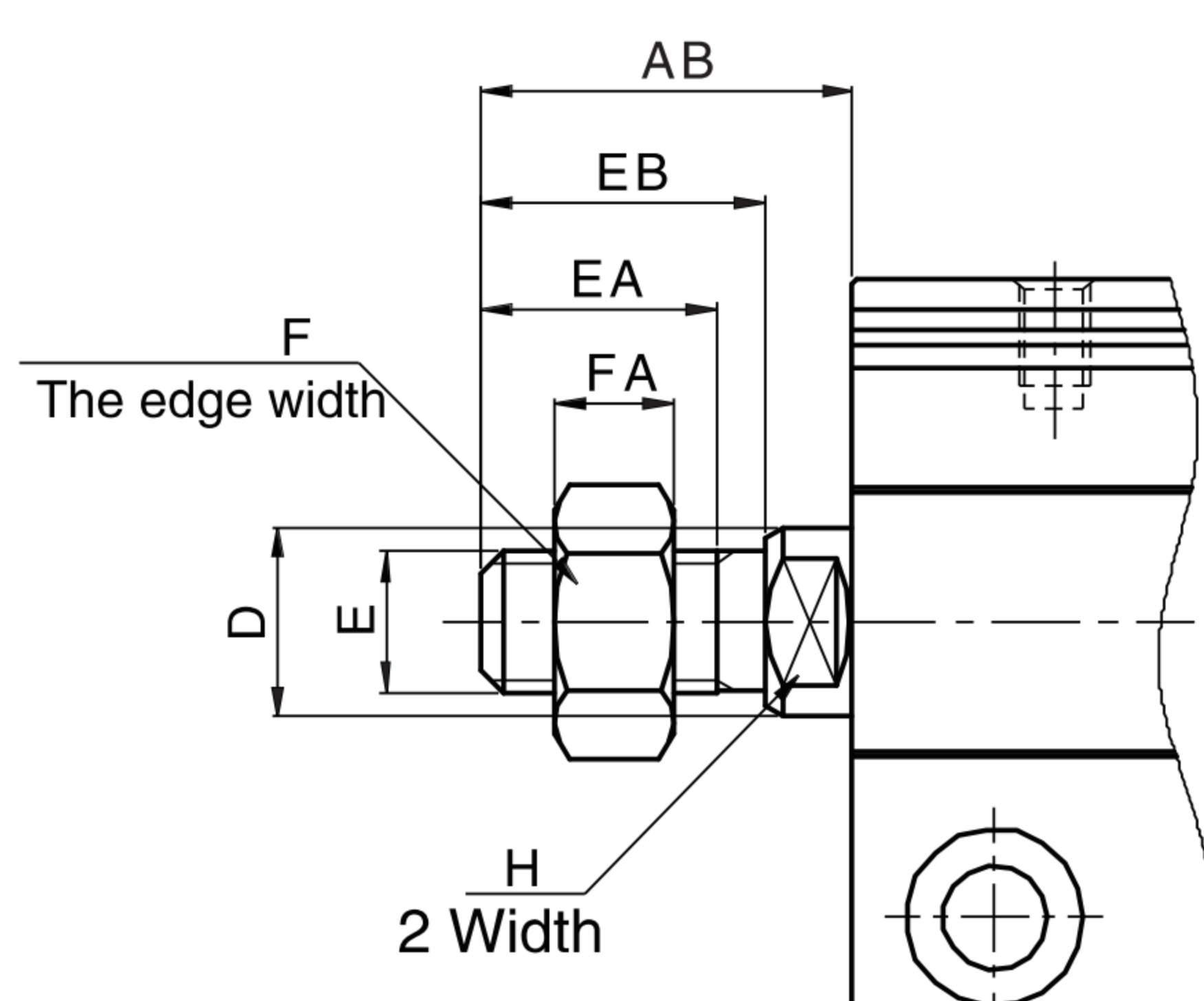

Bore/Sign	AB	D	E	EA	EB	F	FA	H
12	14	6	M5X0.8	9	10.5	8	4	5
16	15.5	8	M6X1.0	10	12	10	5	6
20	18.5	10	M8X1.25	12	14	12	6	8

Note: Not marked dimensions are same sizes as the female type.